



Installation



**An Industry Guide to the Correct
Installation of Windows and Doors**

Foreword

The Australian Window Association is pleased to produce this Industry Guide for the Installation of Windows and Doors as part of its commitment to raising the standard of the built performance of windows and doors in Australia.

Australian Window Association

The AWA is a co-operative of window manufacturers and their suppliers.

The Australian Window Association (AWA) aims are:

- To promote and advance the awareness of windows as a major architectural component in building design.
- To establish and self regulate minimum benchmark standards throughout Australia. To facilitate the education and marketing of these standards throughout the industry and wider community.
- To provide a national voice when representing the industry in discussion and negotiations with government, local authorities, business and trade associations and organisations, and the private sector.
- To promote and encourage ethical conduct and sound business practice in the industry.

Objective

Industry Guide Objective

This Industry Guide to the Installation of Windows and Doors sets out to provide the basic handling and installation instruction for windows and doors in residential buildings. By providing this resource as an instruction guide it is hoped that windows and doors supplied to residential building remain valuable and easy to install and maintain during the construction process.

Acknowledgment

The AWA gratefully acknowledges those member companies whose contribution of materials and continued support to the AWA Technical Committee and its sub committees have made this guide possible.

The AWA specially acknowledges Mr Ian White who is the Executive Manager of Dispute Management Division for the Queensland Building Services Authority. Ian set the Association the challenge to produce this installation guide.

This booklet was designed and printed by Azuma Design

Disclaimer

While the AWA has made every effort to ensure that the material within this guide is accurate, the Australian Window Association will not be liable for any mistakes, errors or omissions arising as a result of information contained in this guide.

| | |
|--|-----------|
| Responsibilities | 2 |
| Extract from Appendix D AS2047 | 2 |
| Methods of identifying windows that comply to AS2047 | 2 |
| The Building Code of Australia | 3 |
| Installation | 3 |
| Certificate | 4 |
| Pre-installation care of windows | 5 |
| Factors that contribute to installation problems | 5 |
| Pre-Installation Care | 5 |
| Installing Frames Correctly | 7 |
| Flashing | 9 |
| General | 9 |
| Jamb Flashing | 9 |
| Head Flashing | 9 |
| Sill Flashing | 10 |
| Special Care | 10 |
| Aluminium Window Installation | 12 |
| Brick Veneer Applications | 12 |
| Cavity Brick Applications | 13 |
| Timber Frame Applications | 14 |
| Concrete Block Applications | 15 |
| Aluminium Door Installation | 16 |
| Brick Veneer Applications | 16 |
| Cavity Brick Applications | 17 |
| Timber Frame Applications | 18 |
| Concrete Block Applications | 19 |
| Timber Window Installation | 20 |
| Brick Veneer Applications | 20 |
| Cavity Brick Applications | 21 |
| Timber Frame Applications | 22 |
| Concrete Block Applications | 23 |

| | |
|---------------------------------|-----------|
| Timber Door Installation | 24 |
| Brick Veneer Applications | 24 |
| Cavity Brick Applications | 25 |
| Timber Frame Applications | 26 |
| Concrete Block Applications | 27 |
| uPVC Window Installation | 28 |
| Brick Veneer Applications | 28 |
| Cavity Brick Applications | 29 |
| Timber Frame Applications | 30 |
| Concrete Block Applications | 31 |
| uPVC Door Installation | 32 |
| Brick Veneer Applications | 32 |
| Cavity Brick Applications | 33 |
| Timber Frame Applications | 34 |
| Concrete Block Applications | 35 |
| AWA Wind Rating Chart | 36 |
| Post Installation Care | 37 |
| Soiling | 37 |
| Door Tracks and Sills | 37 |
| Acid Spills | 37 |
| Use of Hose | 37 |
| Glass Care | 37 |
| Further Information | 39 |

Extract from Appendix D AS2047

1. For housing and other residential buildings the purchaser (building designer or builder) should nominate the window rating (N or C) when ordering the window assemblies.
2. For other buildings the purchaser should nominate the design wind pressures for the window assemblies when ordering the windows.
3. The manufacturer of window assemblies should verify the window rating or design wind pressures.

Methods of identifying windows that comply to AS2047

Labelling

The label should be positioned so that the window can be identified when viewed in situ and have the following information marked on the frame:

a. Housing:

1. Manufacturer's identification mark.
2. Window rating and water penetration resistance.

b. Residential other than housing:

1. Manufacturer's identification mark.
2. Serviceability limit state residential ratings.
3. Ultimate limit state residential ratings.
4. Water penetration resistance.

c. Commercial:

1. Manufacturer's identification mark.
2. Serviceability limit state commercial ratings.
3. Ultimate limit state commercial ratings.
4. Water penetration resistance.

Below is an example of labelling

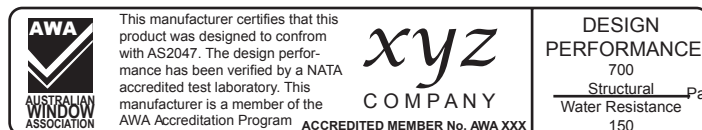

The Building Code of Australia

The Building Code of Australia (BCA) is produced and maintained by the Australian Building Codes Board (ABCB) on behalf of the Australian Government and each State and Territory Government.

The BCA is a uniform set of technical provisions for the design and construction of buildings and other structures throughout Australia. It allows for variations in climate and geological or geographic conditions.

Under part 3.0, section 3.6.0. of the BCA, performance requirements (P2.1 & P2.2.2) are satisfied if windows are designed and constructed in accordance with AS2047. For glazed assemblies not covered by AS2047 compliance to AS1288 is required.

AS2047 - Windows in buildings: Selection and Installation
 AS1288 - Glass in buildings: Selection and Installation

Installation

At all times manufacturer's installation instructions will be the predominant procedure for the installation of proprietary windows.

Installers should ensure that manufacturer's instructions are adopted.

The practices outlined in this guide are not intended to supersede manufacturer's instructions but provide basic and generic guidelines in the absence of such.

Approved PPE (personal protective equipment) should be worn at all times when handling windows.

Special consideration needs to be made for window and door systems designed specifically for acoustics and energy efficiency and reference must be made to building designer or installer for installation details.

Certificate

A certificate, indicating the window rating can be provided for window assemblies. The manufacturer of the window assembly would normally provide this certificate.

Below is an example of a certificate



Pre-installation care of windows

Windows should be stored in a clean, dry area away from cement, lime, paint, acid etc. and must be protected from building materials and loose debris such as wet plaster, mortar, paint and welding splatter.

- Store in a dry location, under cover where possible, to protect against damage
- Carry windows in the verticle position with sashes locked
- Do not rack frames out of square
- Prevent exposure to moisture particularly pooling and ponding
- Do not remove bands from double hung windows until after installation
- Do not remove corner braces until after installation.

Factors that contribute to installation problems

Installation problems such as incorrect fitting or the omission of flashings, smothered or missing weep holes, or the loss of continuity in the water barrier are the prime cause of leaks in window assemblies.

- Severity of exposure to wind is the most important factor in the specification and installation of windows and doors in openings. Components and installation practices acceptable in sheltered situations may quickly fail when exposed to the full force of the wind and rain.
- Follow the window manufacturer's installation specification for the appropriate Terrain Category and height of building; many manufacturers' brochures provide information for sheltered buildings no more than one storey high.

Pre-Installation Care

Installing Frames Correctly

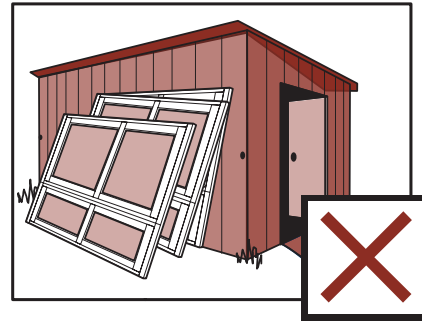
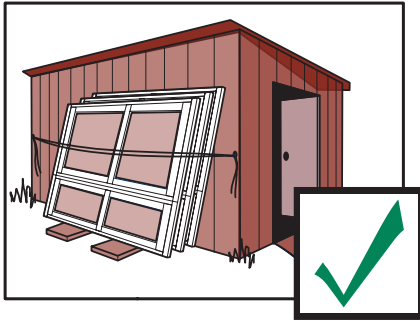

Handle and stack frames carefully on site. Stand them upright on their sills (bottom of the window as installed), raised off the ground on pieces of timber or bricks. Stand them against a flat, vertical surface such as a shed and tie firmly in position.

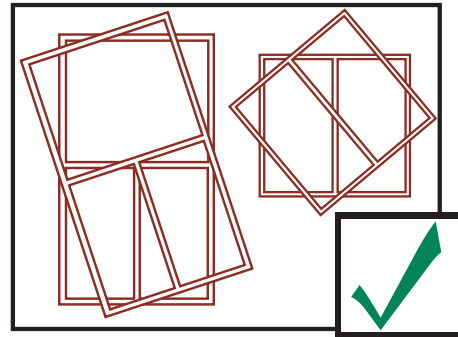
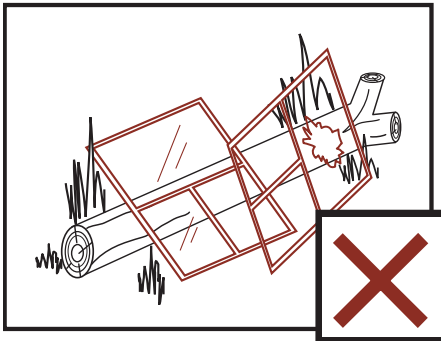

Do not lean windows against a tree or post as they are subject to permanent damage until installed into the building envelope. If the site is bare, lay frames flat on top of each other with weight evenly distributed to avoid buckling and distortion.

1. Fit flashing to window surround as required.
2. Measure the frame opening to ensure that there is sufficient room for the product and additional packing.

Stud Opening:

Height= O/A reveal size + adequate clearance

Width= O/A reveal size + adequate clearance

Clearance dimensions vary between manufacturer's products. For adequate clearance refer to window manufacturer's instruction

3. Frame must be packed plumb, square and not twisted between the openings. Ensure the sill is fully supported; failure to do so may result in sill roll on sliding windows. Sills on all windows and doors must be straight and level and should be packed and secured.
4. Secure aluminum windows by nailing through reveal in brick veneer applications. Timber windows should be secured by back nailing through stud, not face of frame stud. Alternatively, on cavity brick construction use galvanized building lugs located at 450mm maximum centres.
5. If it is not possible to backnail, wedges should be installed between the window and the building frame to prevent opening of the frame joints when nailing is carried out.
6. Keep sashes closed whilst installing frames.
7. Sill bricks should be at least 10 mm clear of window frame to allow settlement in brick veneer construction.
8. Do not stand on the windows or doors, or use them as a support for scaffolding, or slide material through the frame. It is important to prevent any damage to windows and doors during construction.
9. Do not permit weight of eaves or arch bars to bear on any window or door frame. **(Windows and doors are not load bearing)**
10. Remove cement mortar and plaster droppings from windows immediately, taking care to avoid scratching glass and, or frames, as permanent damage can result. Immediate attention must be given by washing off with water before material sets.

11. To ensure the satisfactory long term performance of sliding doors, the sill should be fully supported. Where the sill projects during construction the sill should be fully supported with temporary supports until sill bricks or tiles are installed.

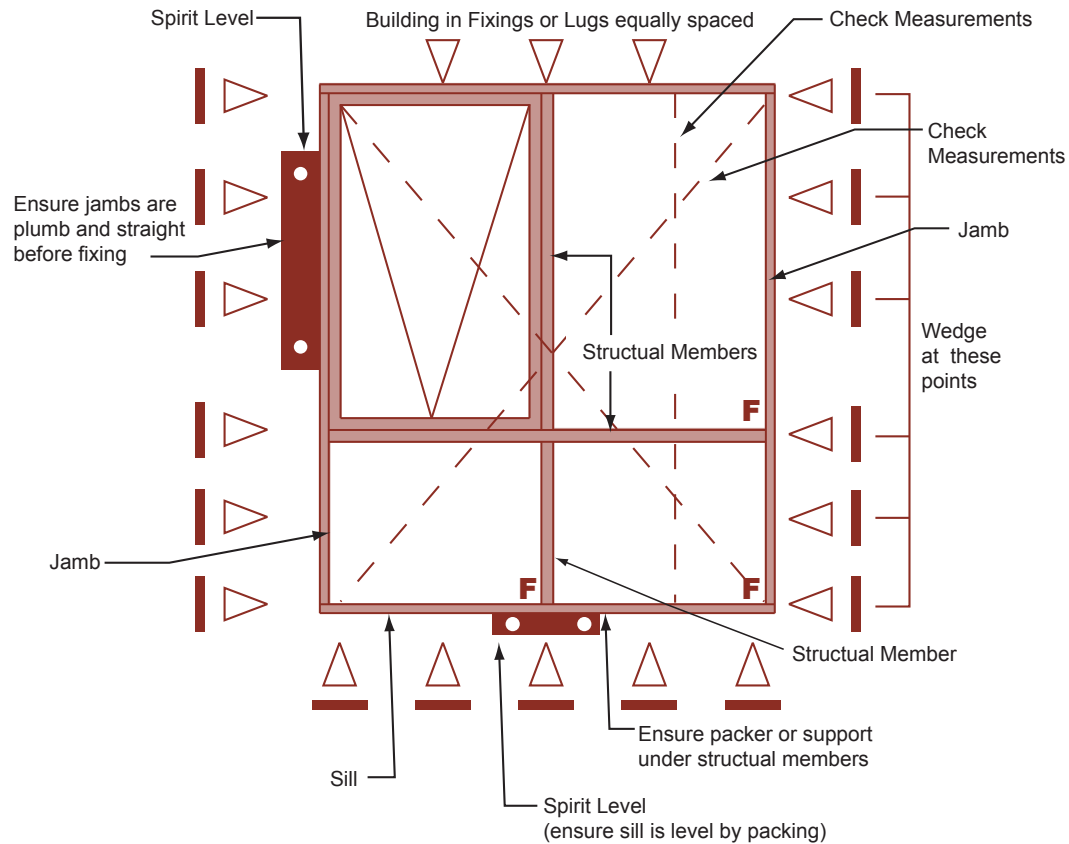

* Fix via building lugs, nails or shim at equally spaced arrow points.

General

It is the builder's responsibility to ensure that windows and doors are installed in such a way that water does not penetrate from the outer skin to the inner skin of the building envelope. The extent of the flashing required will depend on local weather conditions. In some instances only sill flashings may be required. In others jamb and head flashing may be required. For further information please refer to the relevant sections of the B.C.A.

Jamb Flashing

- Required in high wind locations to ensure that water which enters between the window jamb and the outer skin is drained to the sill flashing.
- Where jamb flashing overlaps sill flashing, the overlap should extend the full depth of the sill flashing.

Head Flashing

- Provided to stop water wetting the inner skin by bridging across the window or door head.
- Provided above any wall penetrations not specifically designed to stop water reaching the inner skin, ie; exhaust fans and ventilation ducts.
- Must project horizontally a minimum of 150mm both sides past the opening.
- Must be of approved materials to AS2904 and bonded at laps.
- Must be provided with weep holes to let the water out.

Sill Flashing

- Provided to stop water entering across underside of the window and wetting the inner skin.
- The window generates run off in down pours and sill flashing stops this water being blown across the cavity under the window.
- Some windows have drain holes which also direct water downwards into the cavity. The sill flashing also collects water which runs down the jamb flashing.
- Must project a minimum of 150mm both sides past the opening.
- Must be of approved materials to AS2904 and bonded at laps.
- The brickwork must be provided with weep holes to let the water out.

Special Care

- Special care is required on windows with undersill drainage used in a non cavity situation such as single skin block work.
- Where a subsill is used stop ends must be fitted and sealed.

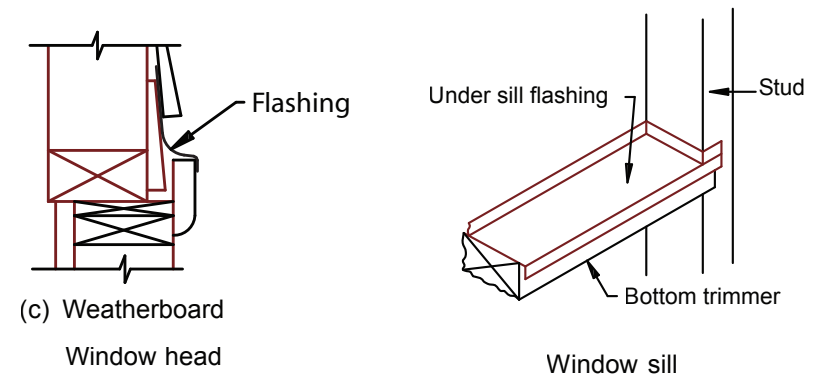
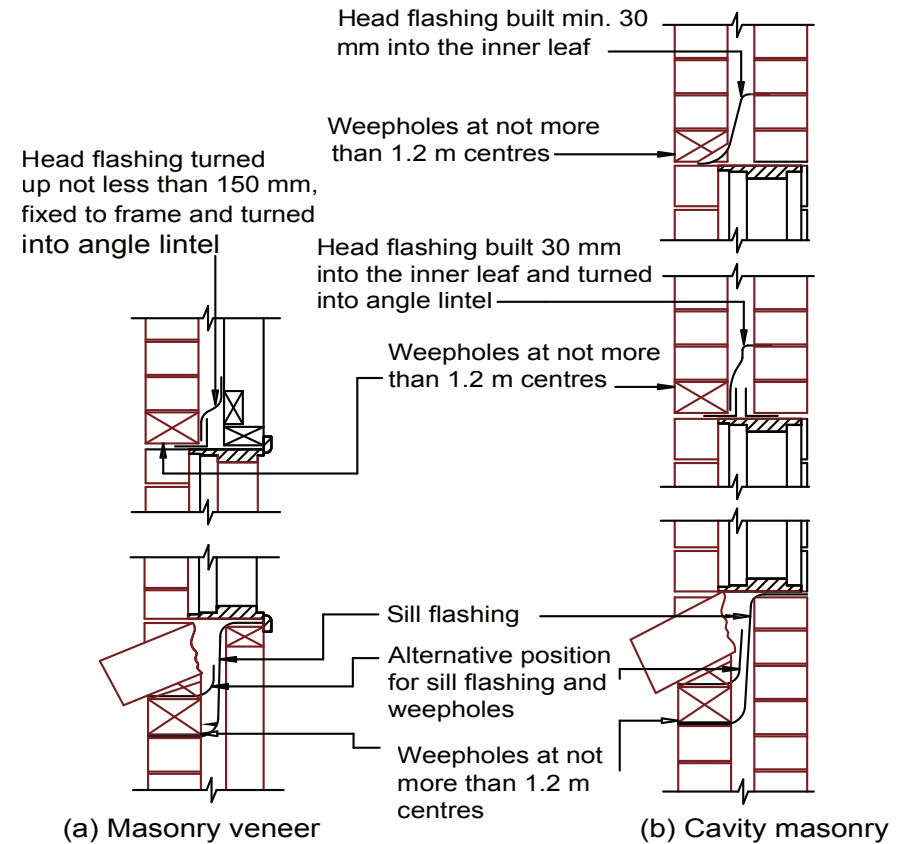

Brick Veneer Applications

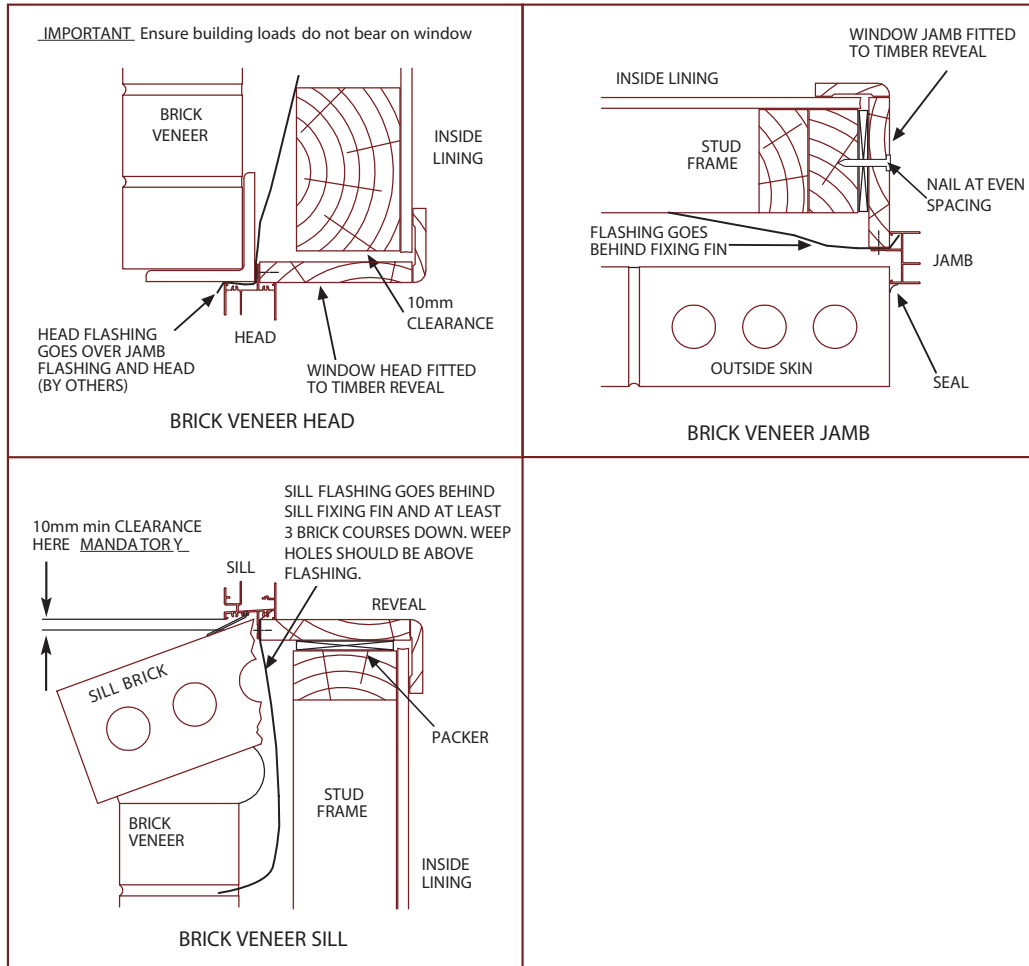

Cavity Brick Applications

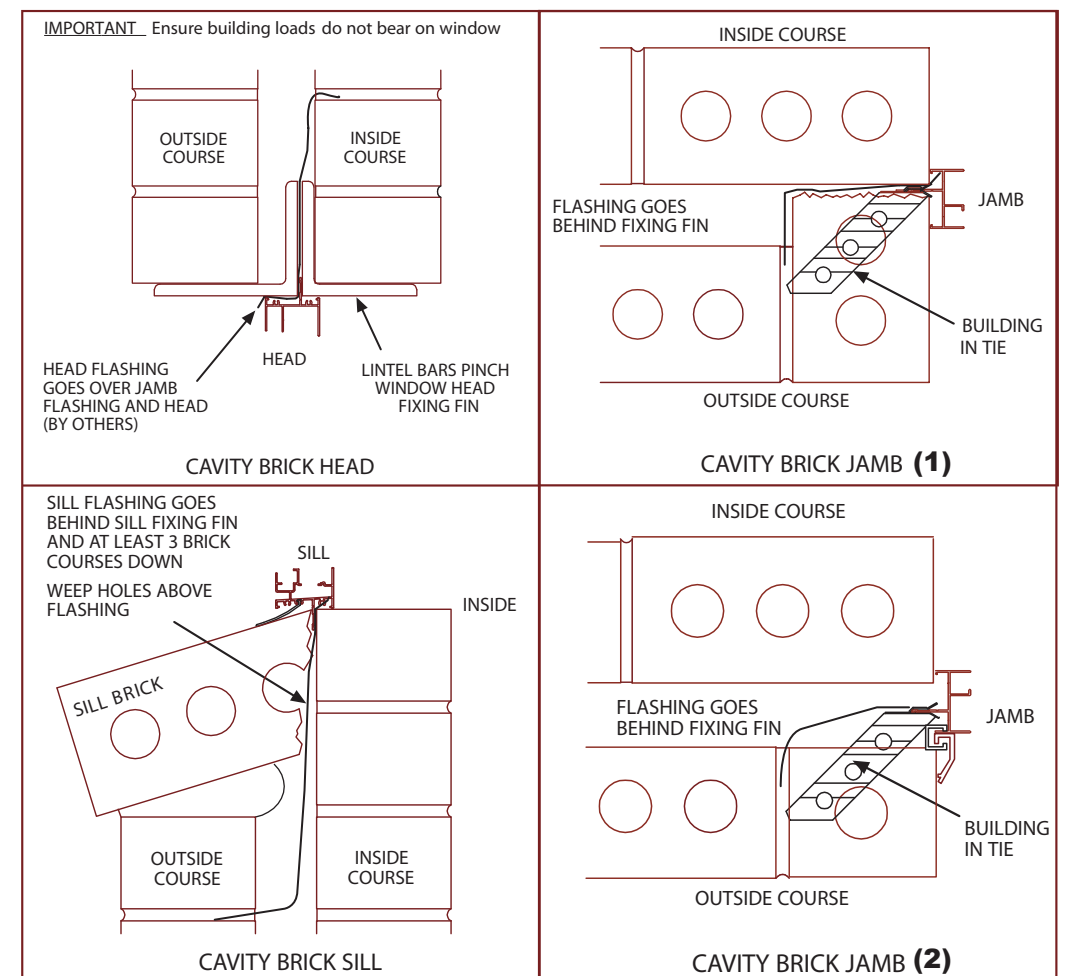

Timber Frame Applications

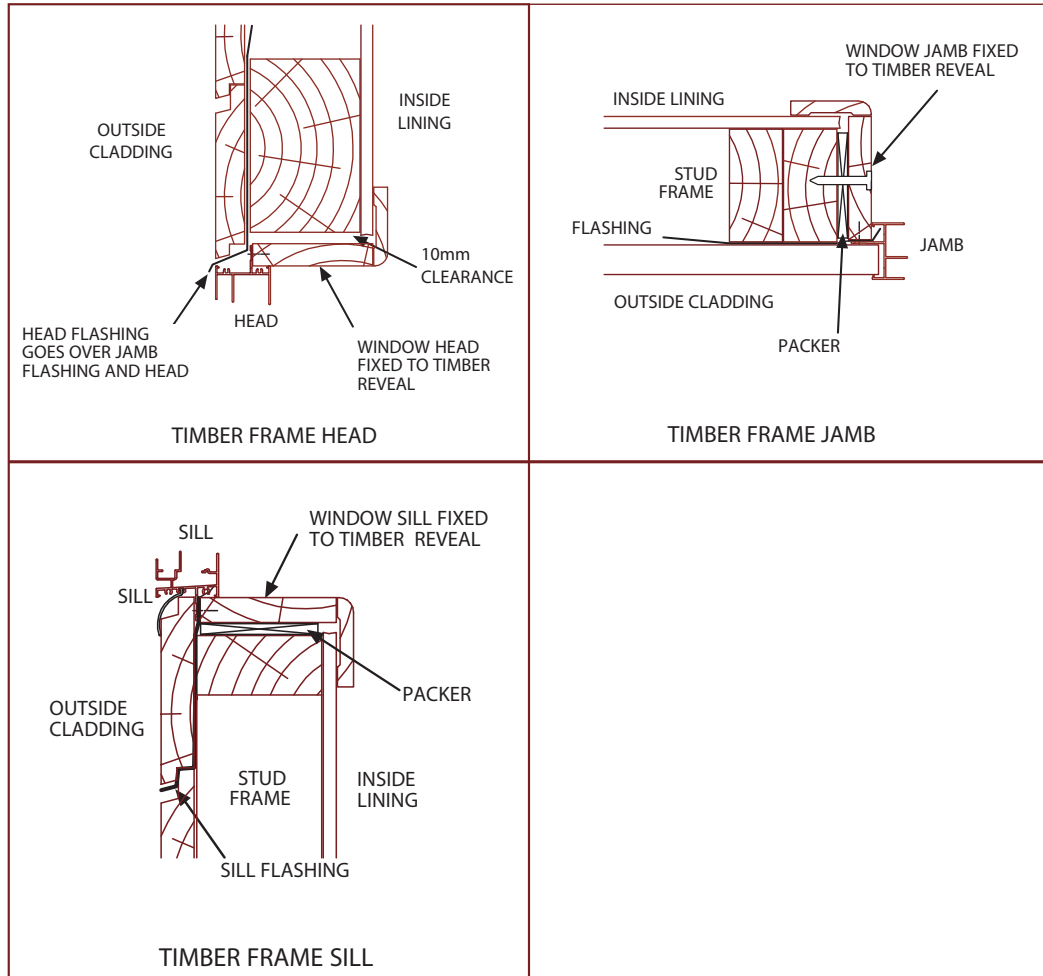

Concrete Block Applications

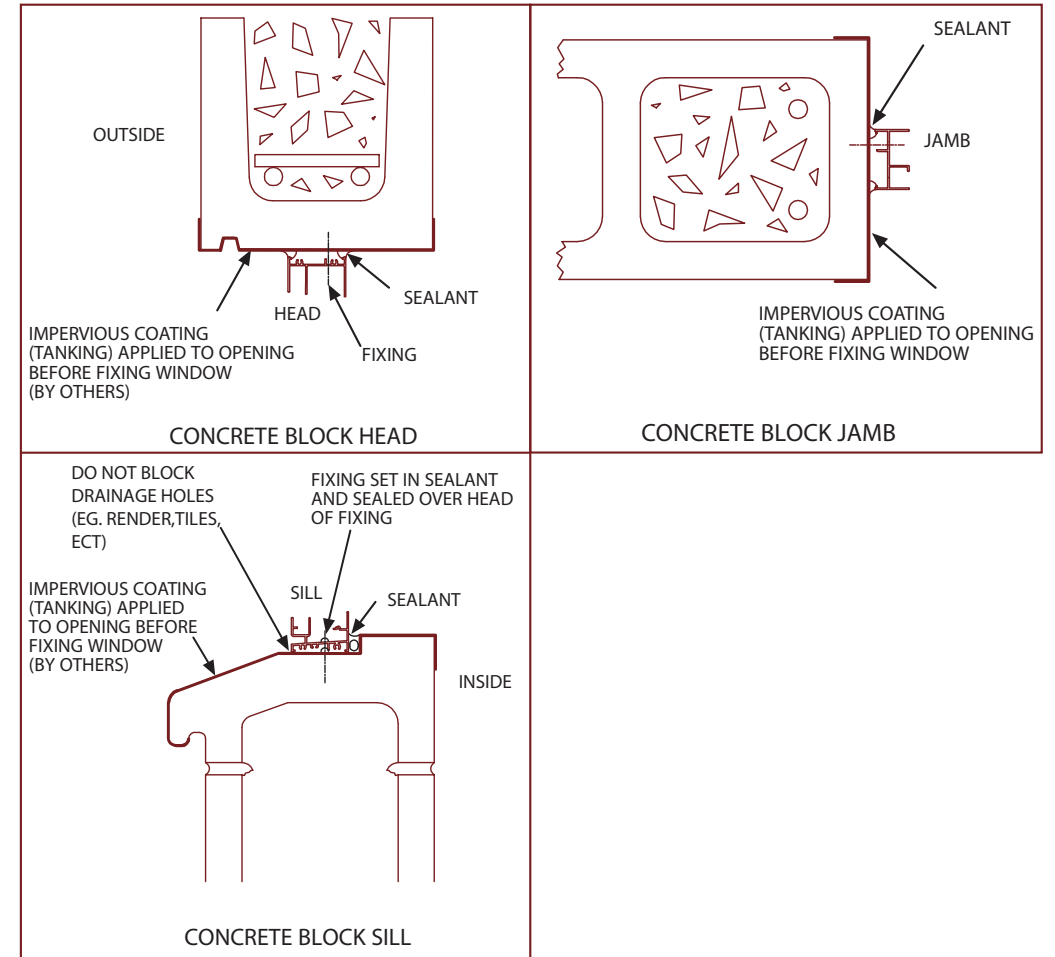

Brick Veneer Applications

IMPORTANT Ensure building loads do not bear on door

BRICK VENEER HEAD
 BRICK VENEER
 INSIDE LINING
 HEAD FLASHING GOES OVER JAMB FLASHING AND HEAD (BY OTHERS)
 HEAD
 DOOR HEAD FITTED TO TIMBER REVEAL
 10mm CLEARANCE

BRICK VENEER JAMB
 INSIDE LINING
 STUD FRAME
 FLASHING GOES BEHIND FIXING FIN
 JAMB
 DOOR JAMB FITTED TO TIMBER REVEAL
 OUTSIDE SKIN

SEALANT OVER HEAD OF FIXING AND SET FIXING IN SEALANT (TO REINSTATE FLASHING)
 SILL
 PACK SILL TO LEVEL WHERE REQUIRED
 FLASHING (MANDATORY) (BY OTHERS)
 OUTSIDE

IMPORTANT
 Separate the sill and outside brick skin with an isolator to prevent possible reaction between brick / mortar and the aluminium framing which can lead to extensive corrosion.
 Sill must be level side to side and front to back, and fully supported at all times

BRICK VENEER SILL

Cavity Brick Applications

IMPORTANT Ensure building loads do not bear on door

CAVITY BRICK HEAD
 OUTSIDE COURSE
 INSIDE COURSE
 HEAD FLASHING GOES OVER JAMB FLASHING AND
 HEAD
 LINTEL BARS PINCH DOOR FIXING FIN

CAVITY BRICK JAMB
 INSIDE SKIN
 FLASHING GOES BEHIND FIXING FIN
 JAMB
 BUILDING IN TIE
 OUTSIDE SKIN

SEALANT OVER HEAD OF FIXING AND SET FIXING IN SEALANT (TO REINSTATE FLASHING)
 SILL
 FLASHING (MANDATORY)
 OUTSIDE
 INSIDE FLOOR
 PACK SILL WHERE REQUIRED TO LEVEL

IMPORTANT
 Separate the sill and outside brick skin with an isolator to prevent possible reaction between brick / mortar and the aluminium framing which can lead to extensive corrosion.
 Sill must be level side to side and front to back, and fully supported at all times

CAVITY BRICK SILL

Timber Frame Applications

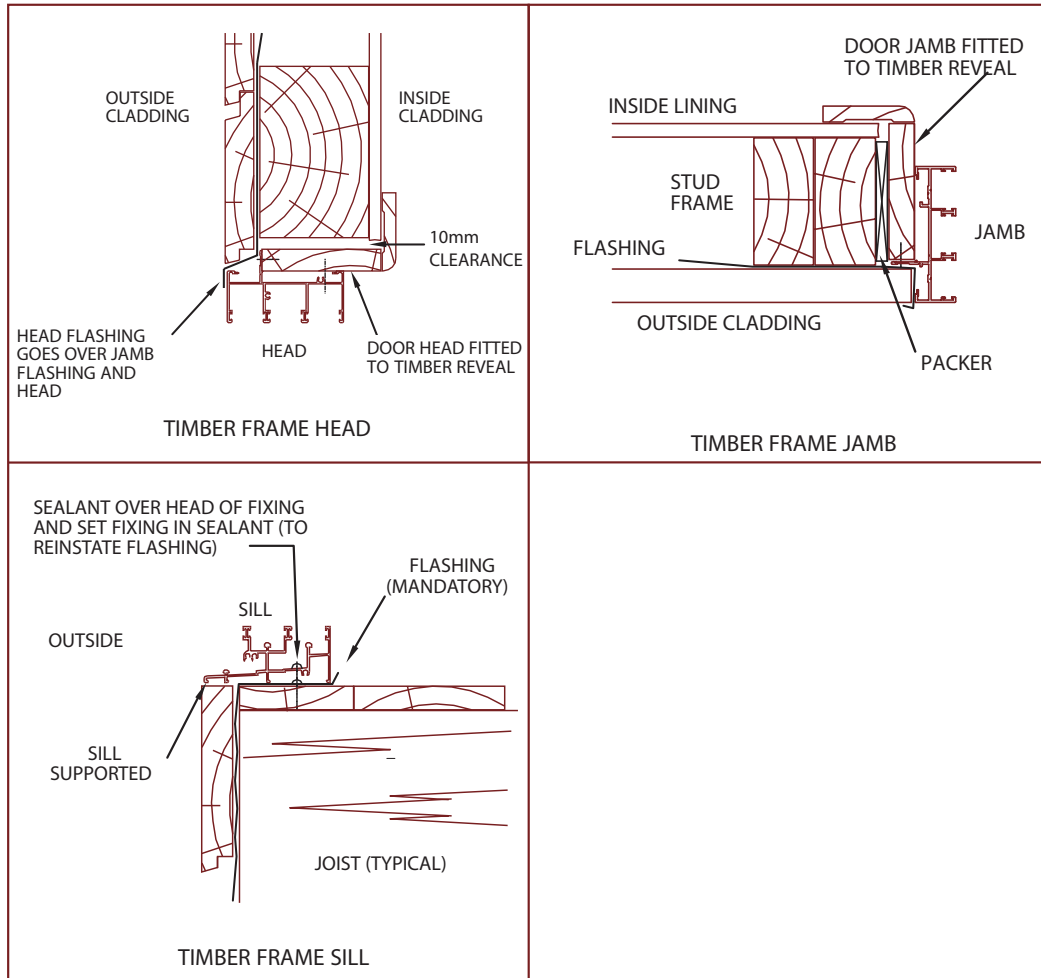

Concrete Block Applications

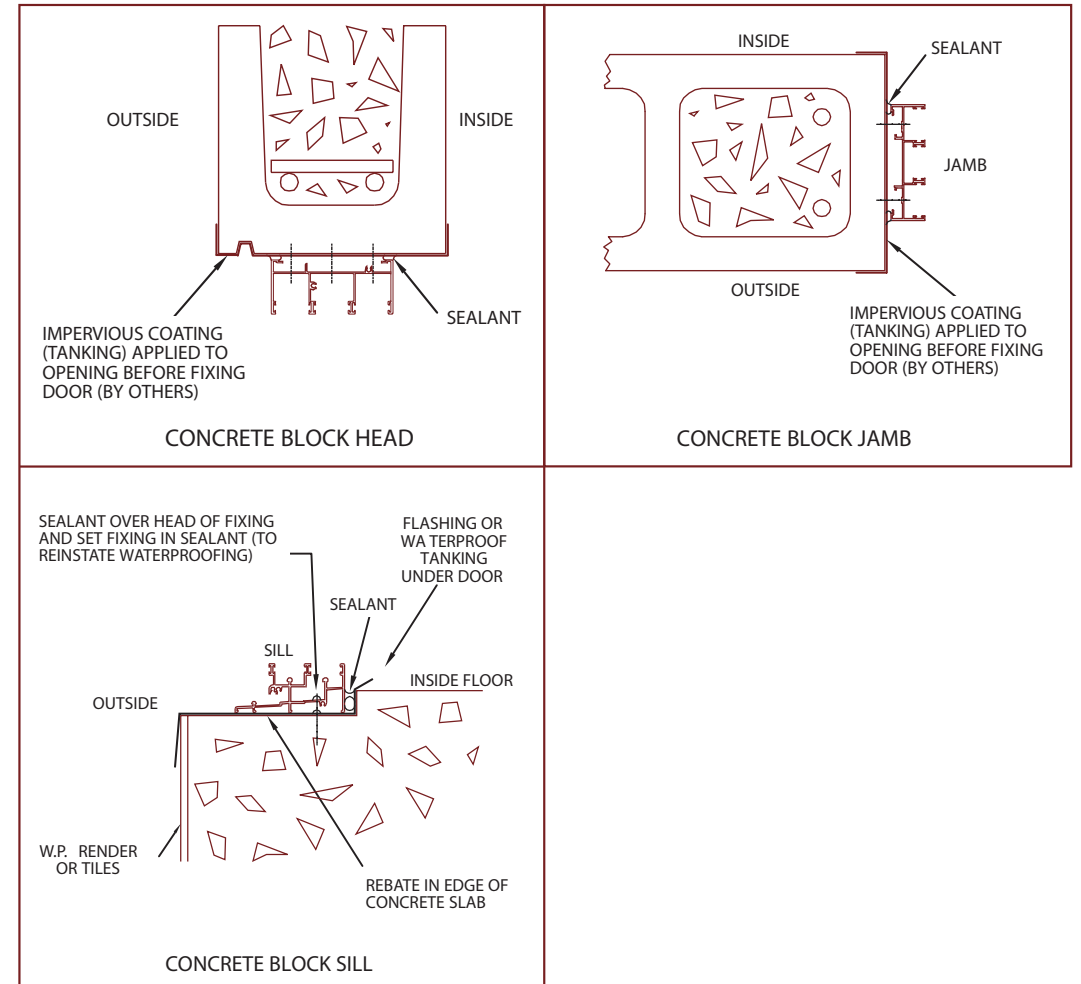

Brick Veneer Applications

Cavity Brick Applications

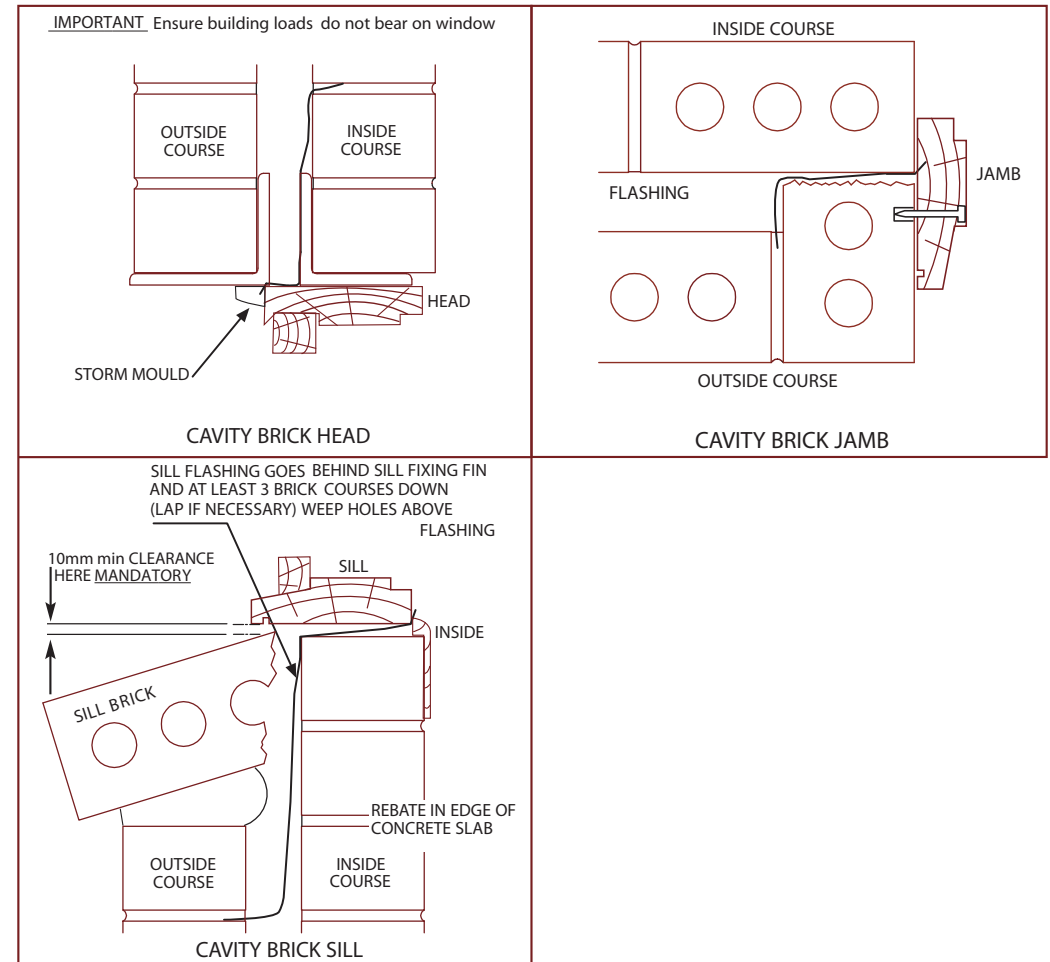
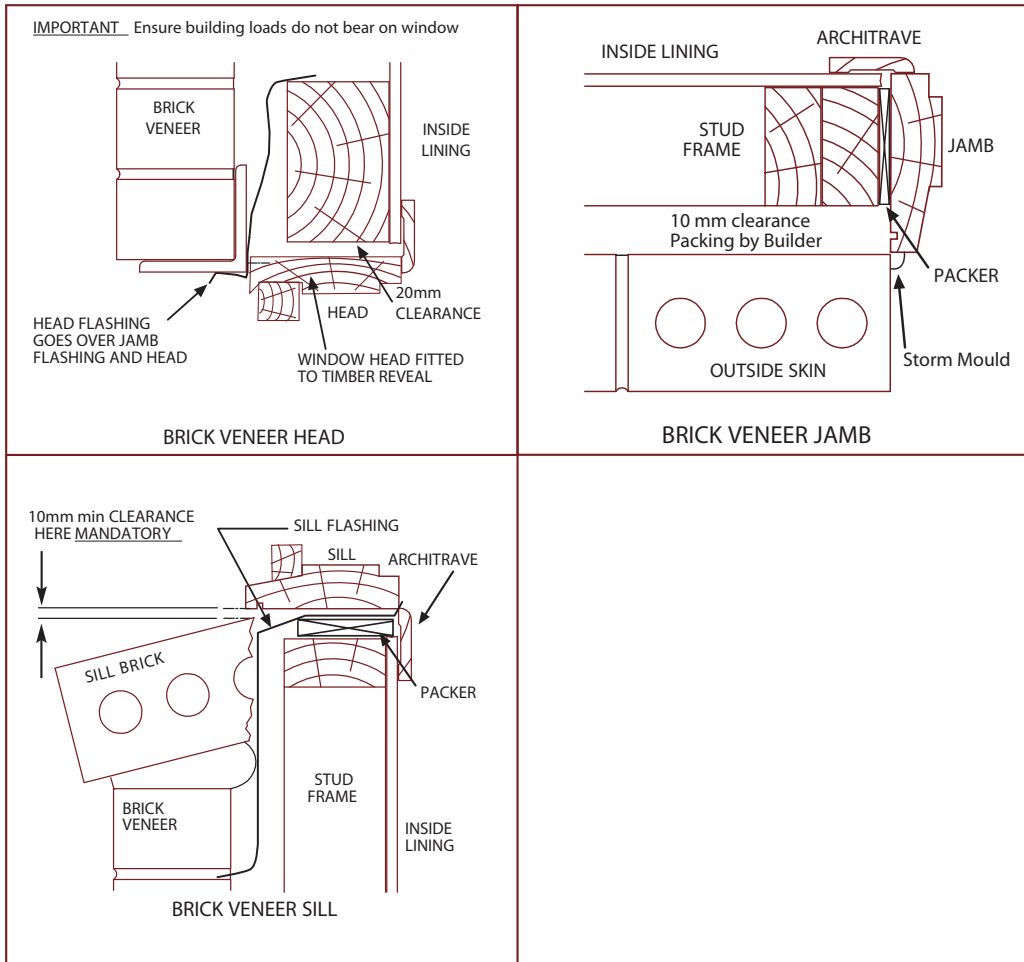

Timber Frame Applications

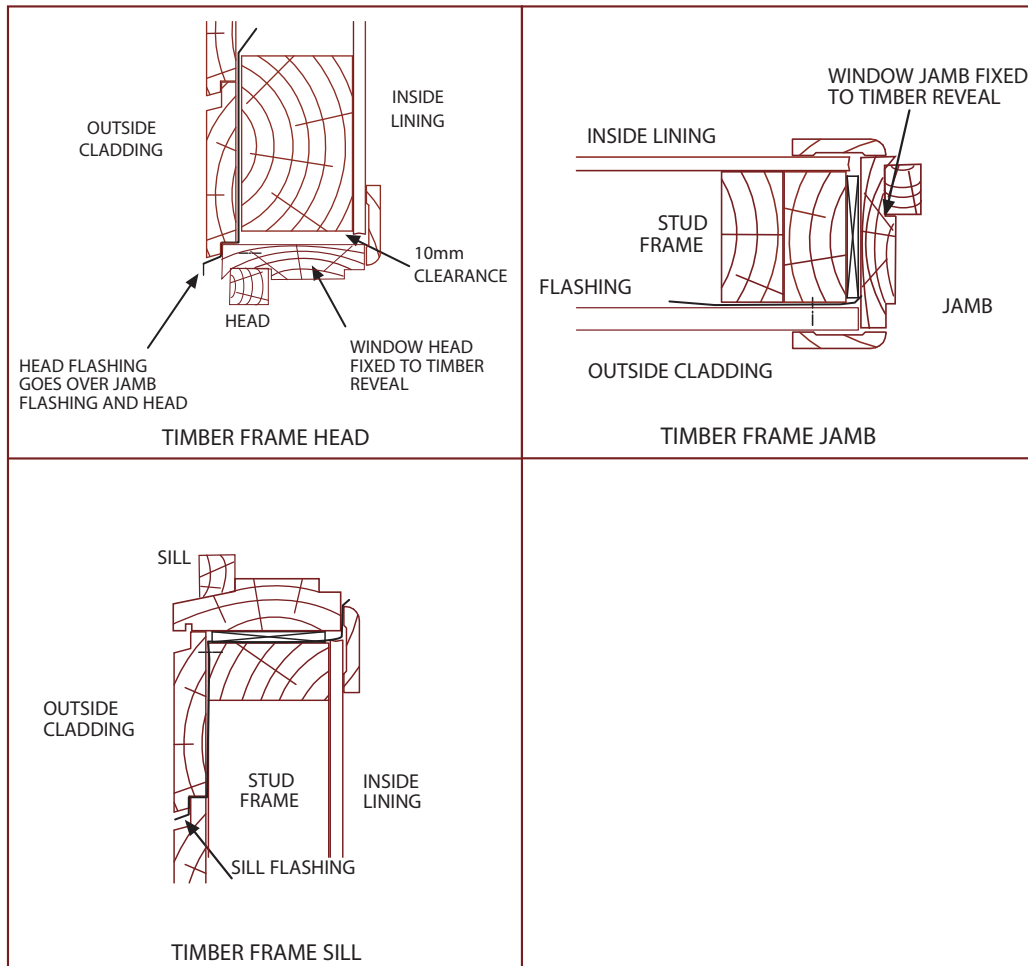

Concrete Block Applications

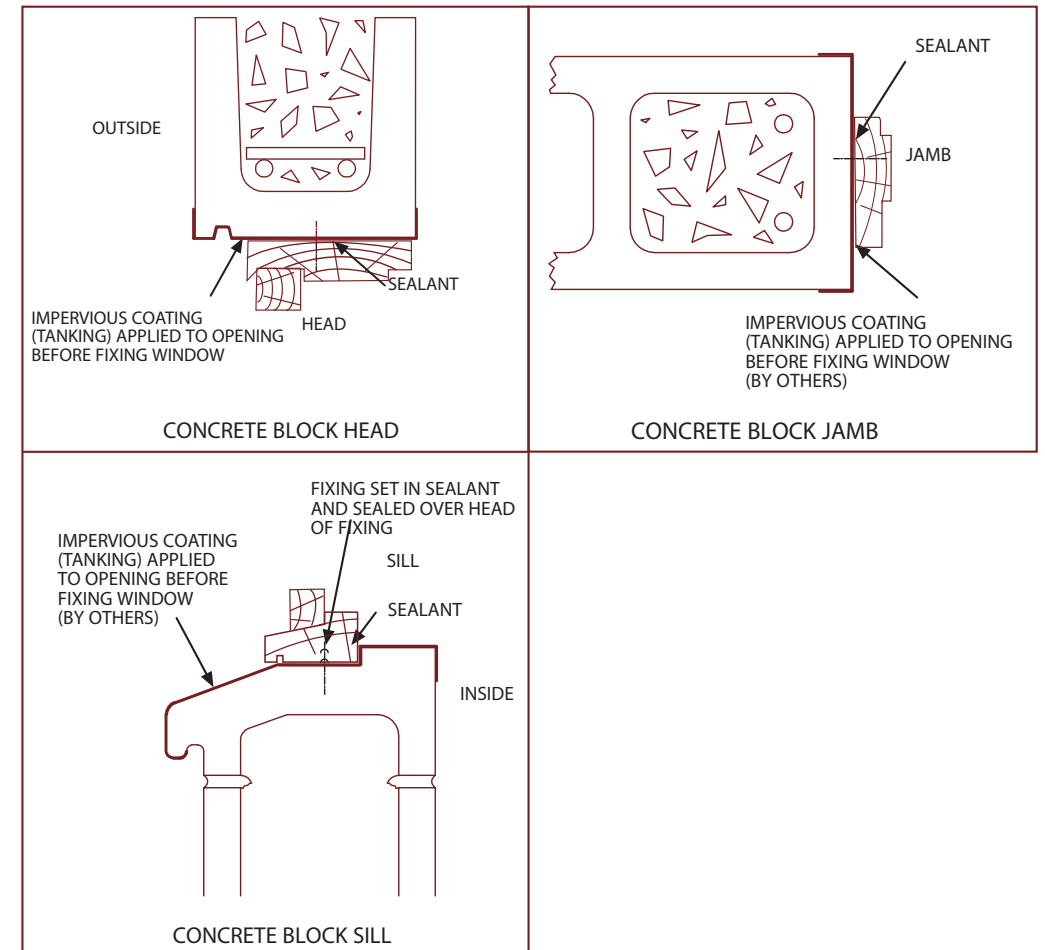

Brick Veneer Applications

Cavity Brick Applications

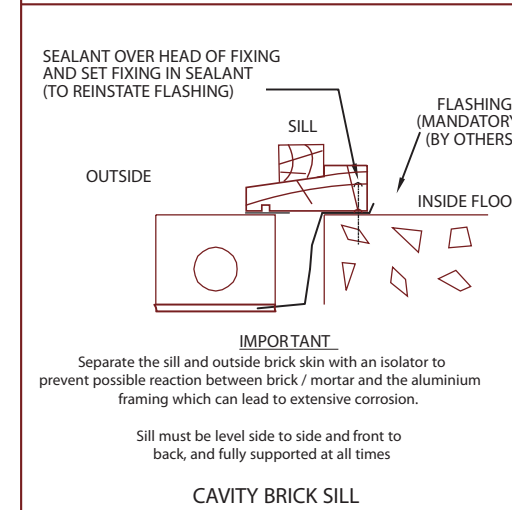
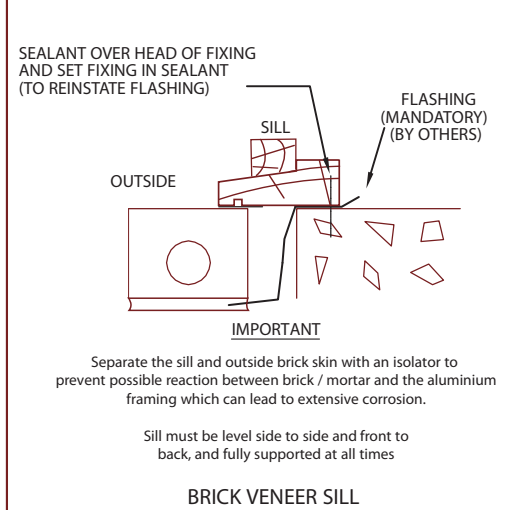
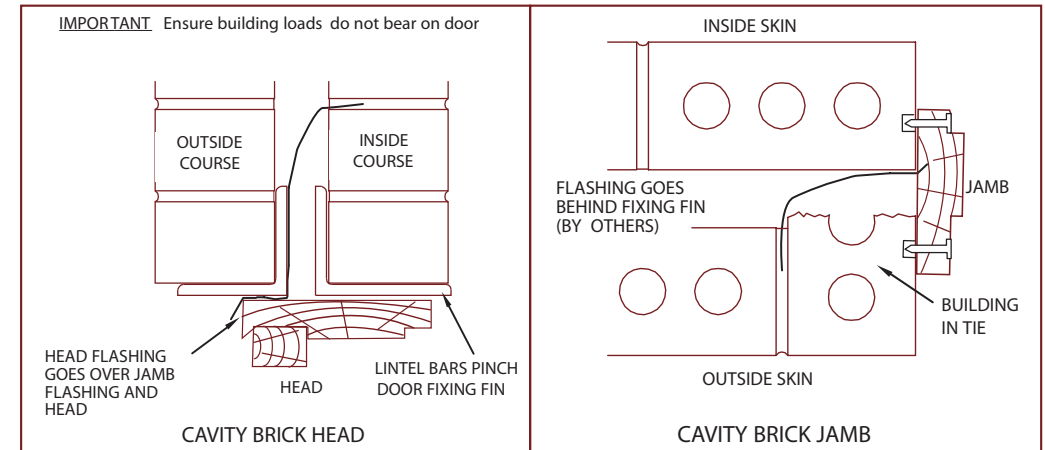
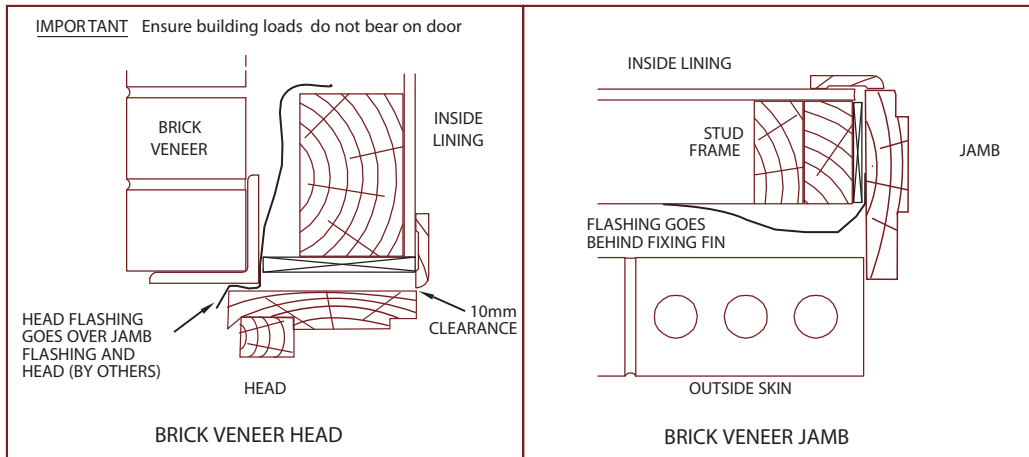

Timber Frame Applications

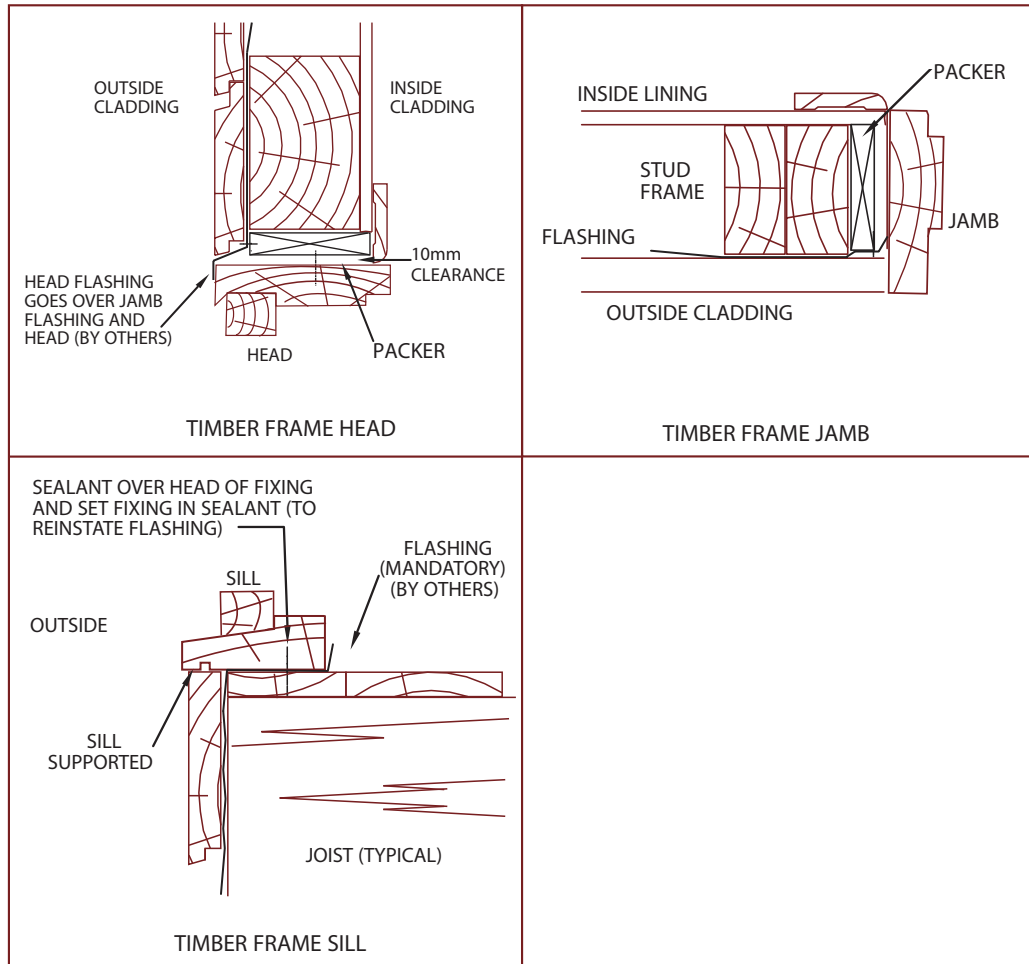

Concrete Block Applications

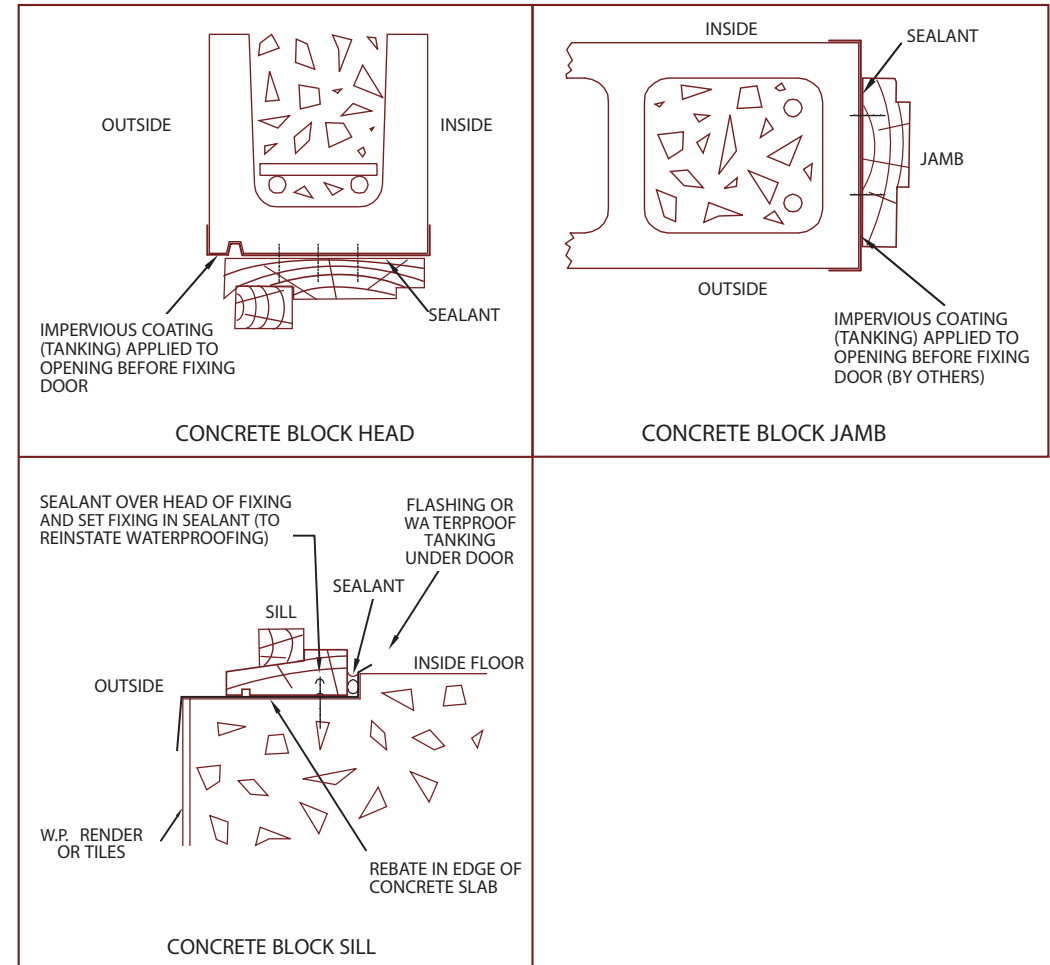

Brick Veneer Applications

Cavity Brick Applications

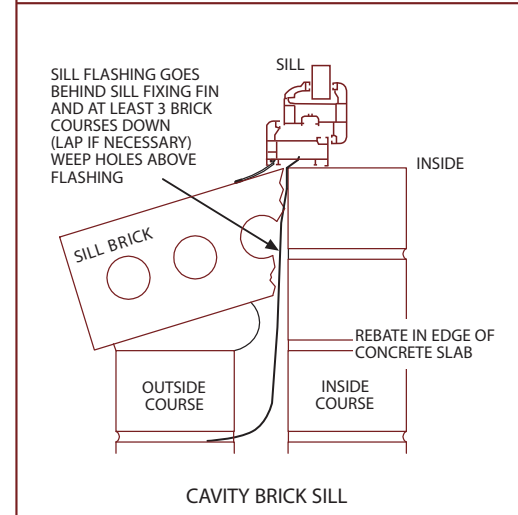
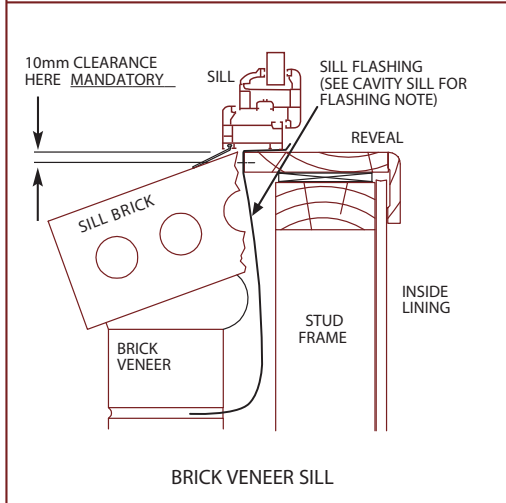
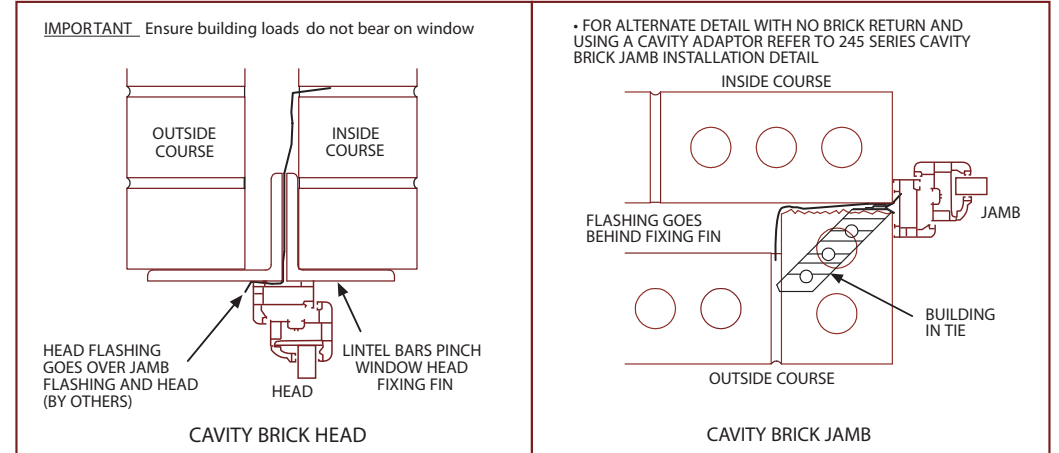
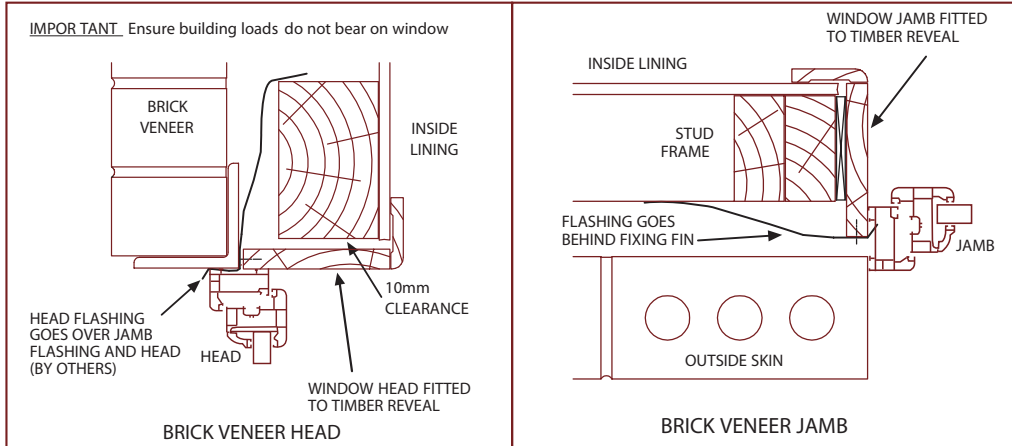

Timber Frame Applications

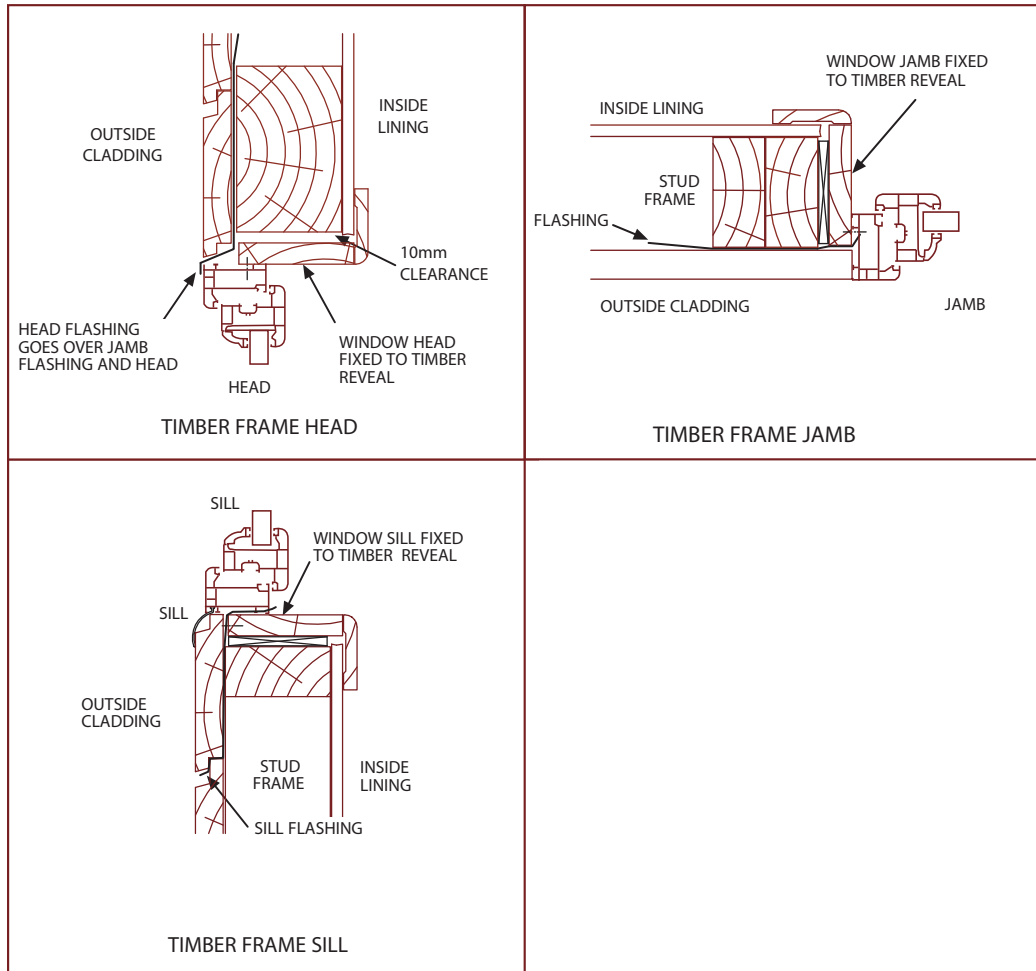

Concrete Block Applications

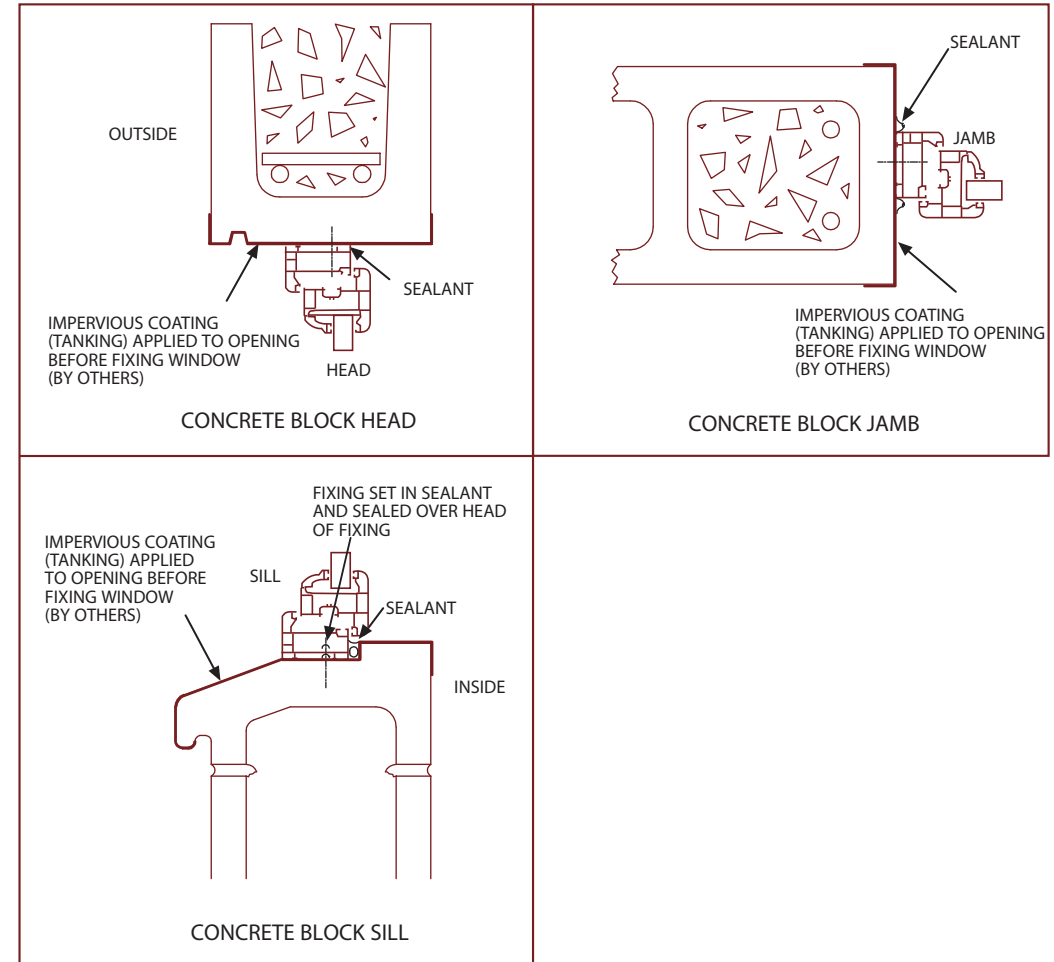

Brick Veneer Applications

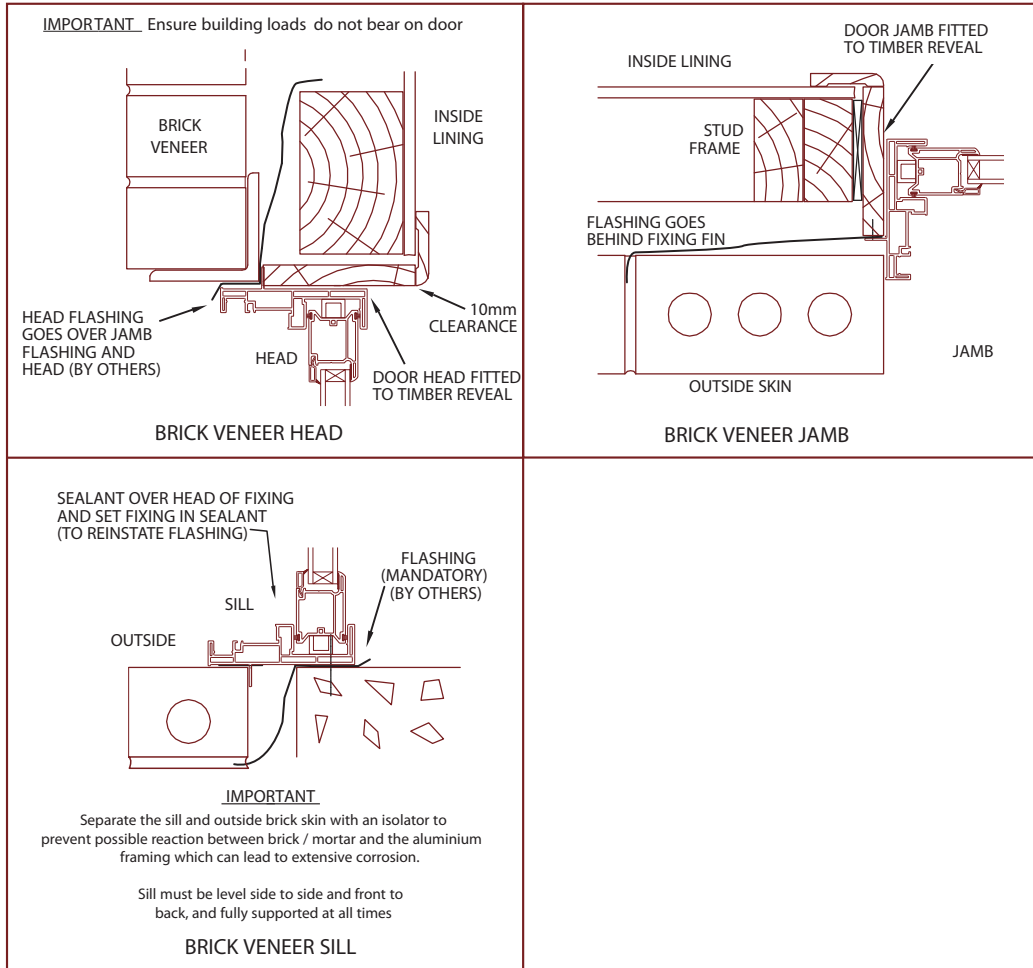

Cavity Brick Applications

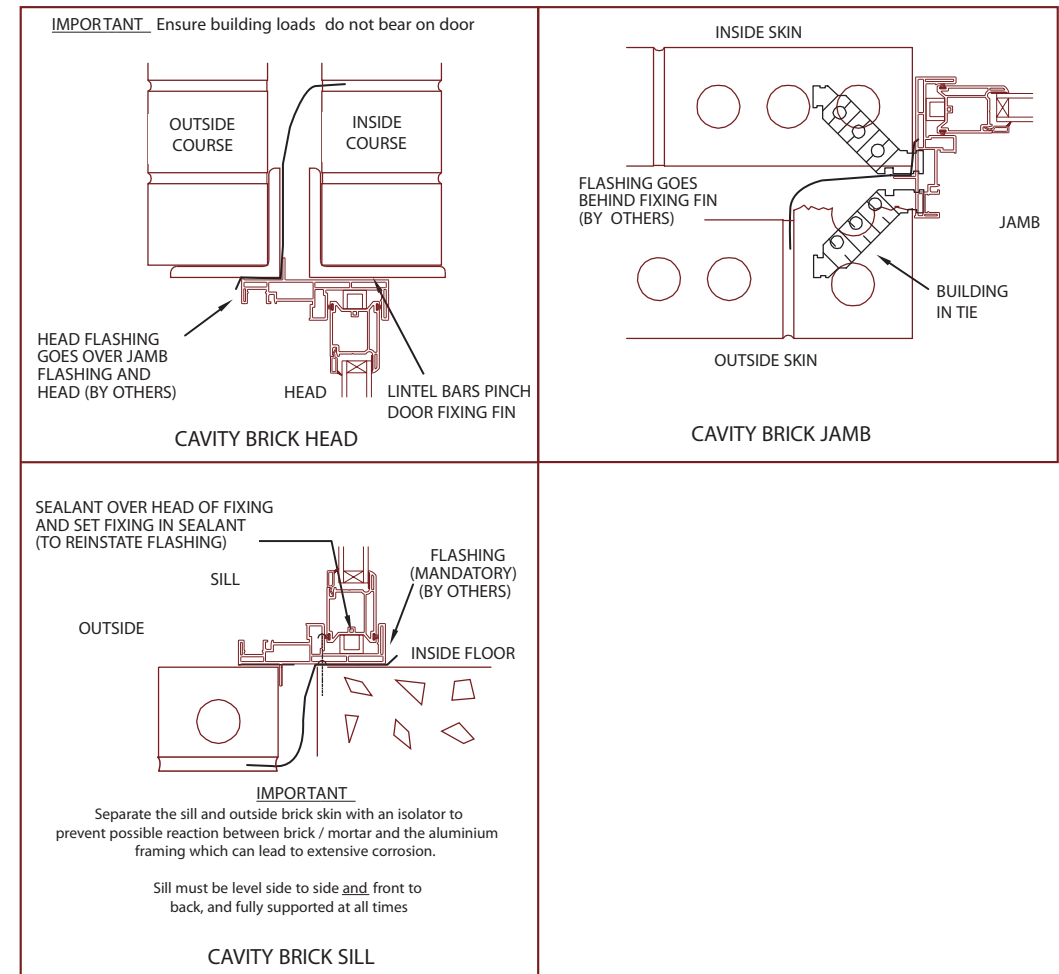

Timber Frame Applications

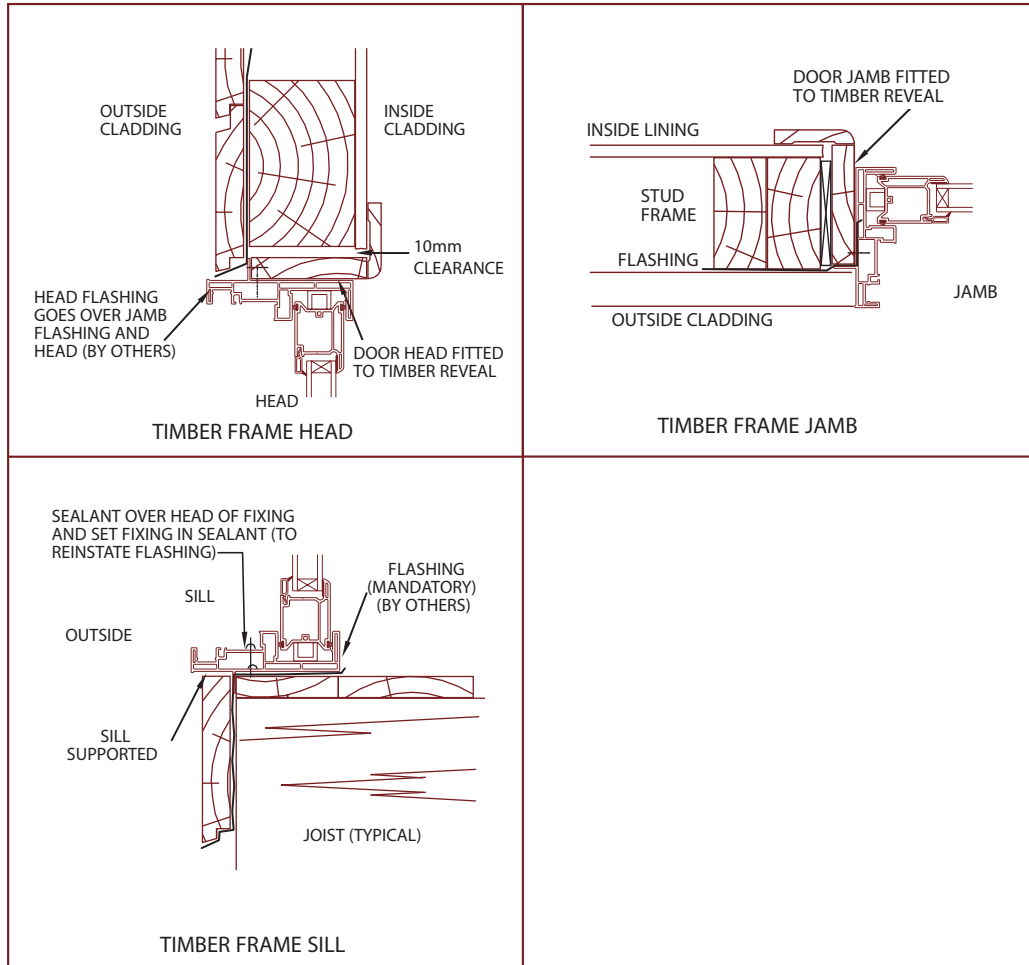

Concrete Block Applications

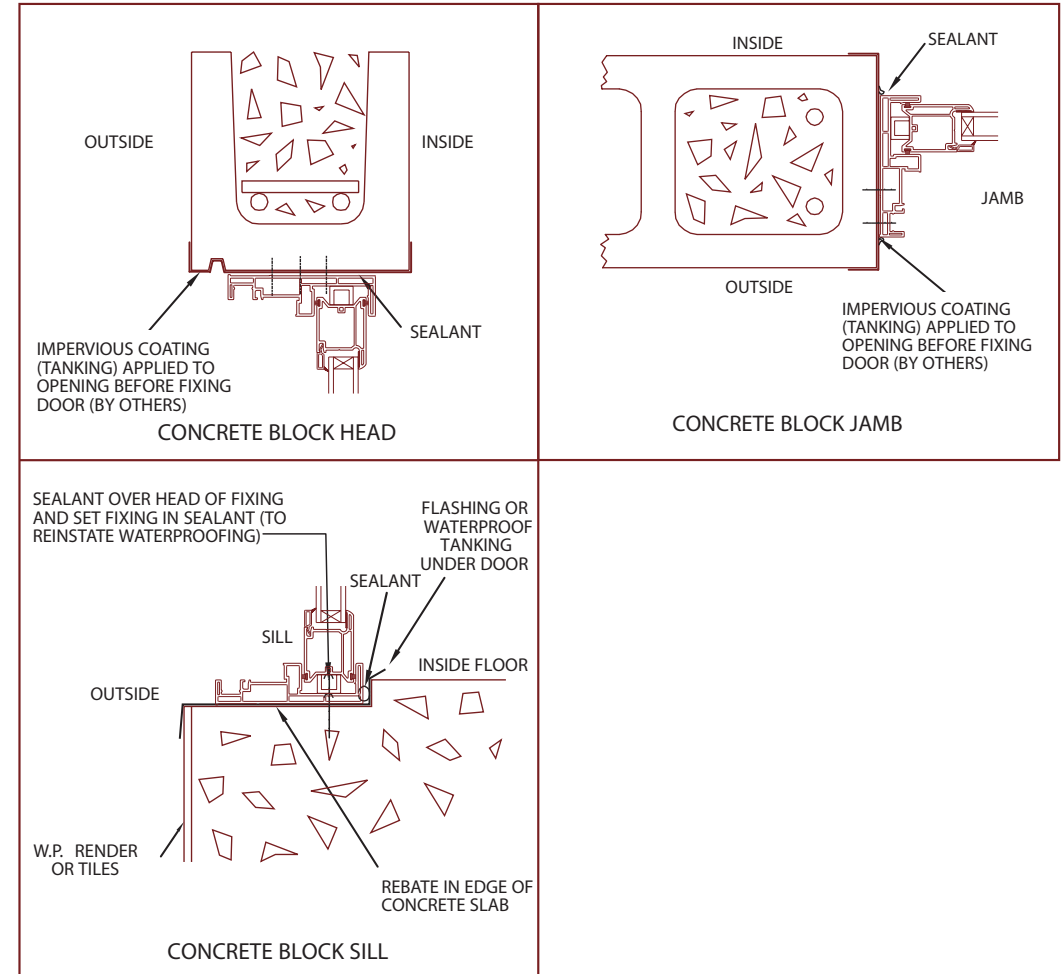

STATIC PRESSURES QUICK CONVERSION CHART

| Pascals | m/s | Km/h | mm H ₂ O | MPH | PSF |
|---------|--------|--------|---------------------|--------|--------|
| 75 | 11.18 | 40.25 | 7.65 | 25.01 | 1.56 |
| 100 | 12.91 | 46.48 | 10.20 | 28.88 | 2.08 |
| 150 | 15.81 | 56.92 | 15.30 | 35.36 | 3.13 |
| 200 | 18.26 | 65.73 | 20.40 | 40.84 | 4.17 |
| 250 | 20.41 | 73.48 | 25.50 | 45.88 | 5.22 |
| 300 | 22.36 | 80.50 | 30.60 | 50.02 | 6.26 |
| 400 | 25.82 | 92.95 | 40.80 | 57.75 | 8.35 |
| 500 | 28.87 | 103.92 | 51.00 | 64.75 | 10.44 |
| 600 | 31.62 | 113.84 | 61.20 | 70.73 | 12.53 |
| 700 | 34.16 | 122.69 | 71.40 | 76.23 | 14.62 |
| 800 | 36.51 | 131.45 | 81.60 | 81.67 | 16.71 |
| 900 | 38.73 | 139.43 | 91.80 | 86.63 | 18.80 |
| 1000 | 40.82 | 146.97 | 102.00 | 91.32 | 20.89 |
| 1100 | 42.82 | 154.14 | 112.20 | 95.77 | 22.97 |
| 1200 | 44.72 | 161.00 | 122.40 | 100.04 | 25.06 |
| 1300 | 46.55 | 167.57 | 132.60 | 104.12 | 27.15 |
| 1400 | 48.30 | 173.90 | 142.80 | 108.05 | 29.24 |
| 1500 | 50.00 | 180.00 | 153.00 | 111.84 | 31.33 |
| 1600 | 51.64 | 185.90 | 163.20 | 115.51 | 33.42 |
| 1700 | 53.23 | 191.62 | 173.40 | 119.06 | 35.51 |
| 1800 | 54.77 | 197.18 | 183.60 | 122.52 | 37.60 |
| 1900 | 56.27 | 202.58 | 193.80 | 125.87 | 39.69 |
| 2000 | 57.74 | 207.85 | 204.00 | 129.15 | 41.78 |
| 2100 | 59.16 | 212.98 | 214.20 | 132.33 | 43.86 |
| 2200 | 60.55 | 218.00 | 224.40 | 135.45 | 45.95 |
| 2300 | 61.91 | 222.90 | 234.60 | 138.50 | 48.04 |
| 2400 | 63.25 | 227.68 | 244.80 | 141.47 | 50.13 |
| 2500 | 64.55 | 232.38 | 255.00 | 144.39 | 52.22 |
| 3000 | 70.71 | 254.56 | 306.00 | 158.17 | 62.67 |
| 4000 | 81.65 | 293.94 | 408.00 | 182.64 | 83.56 |
| 5000 | 91.29 | 328.63 | 510.00 | 204.20 | 104.45 |
| 6000 | 100.00 | 360.00 | 612.00 | 223.69 | 125.34 |

DISCLAIMER: Any advice, recommendation, information, assistance or service provided by the AWA in relation to the above is given in good faith and is believed by the parties to be appropriate, but is given without any liability or responsibility on the AWA's behalf.

Soiling:

If removal of debris is delayed and scraping becomes necessary the finish may be damaged. Remove cement, mortar and other droppings immediately, using ample clean water and a sponge or rag to avoid permanent staining of finished surfaces.

Door Tracks and Sills:

Door tracks and window sills should be protected from planks, scaffolding and barrows.

Acid Spills:

Acid used for cleaning brickwork MUST be prevented from making contact with powdercoated or anodised aluminium windows and door surfaces. If any acid or similar corrosive material does come into contact with window or door surfaces those areas must be washed IMMEDIATELY with large quantities of clean water.

Use of Hose

If using a hose or similar apparatus to clean windows and/or doors ensure the hose nozzle/jet fitting is set to a fine spray as shown in the diagram. At NO time should a window or door be hit with a full force of a hose, nozzle/jet setting.

Glass Care

- To clean, simply wipe over the surface with a few drops of methylated spirits on a damp cloth, then polish the surface dry with a lint free cloth.
- Ensure that all cleaning cloths are free from any abrasive surfaces.
- Never remove abrasive materials such as mortar from the glass with a scraper. (To clean, flood with water and dab with a sponge. Dont scub with sponge or scratching will occur.)

Soiling

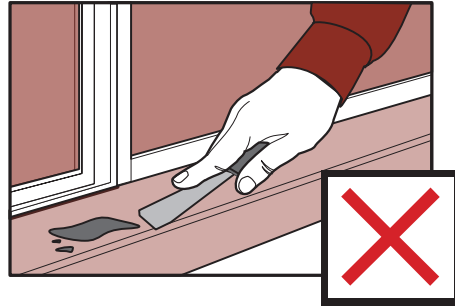
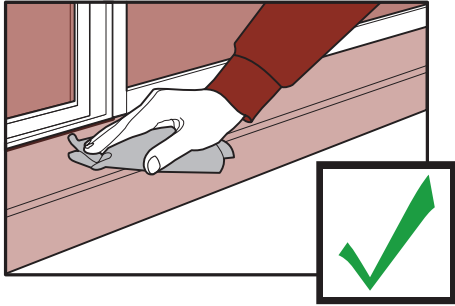

Door tracks & sills

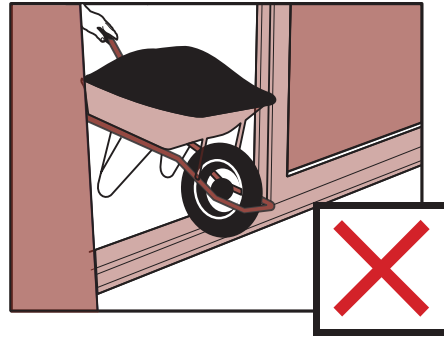
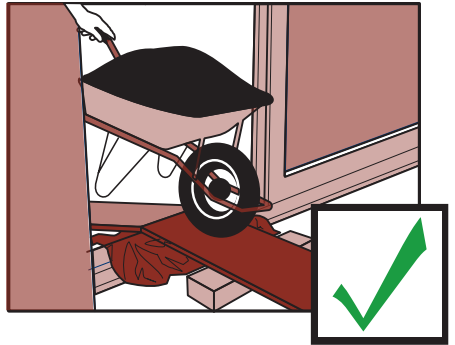

Cleaning

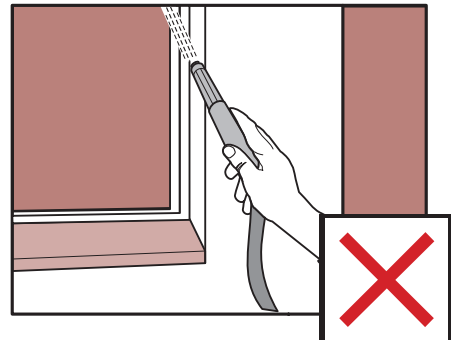
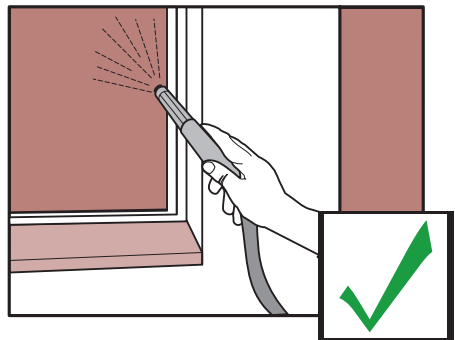

Australian Aluminium Council
www.aluminium.org.au

Australian Building Codes Board
www.abcb.gov.au

Australian Vinyl Council
www.vinyl.org.au

Australian Window Association
www.awa.org.au

BUILDdata - Building Products Information Service
www.buildata.com.au

HIA (Housing Industry Association)
www.buildingonline.com.au

Master Builders Association
www.masterbuilders.com.au

Office of Fair Trading & Home Building Services
www.fairtrading.nsw.gov.au

Standards Australia
www.standards.com.au

Timber Development Association
www.timber.net.au

WERS.net - website for the Window Energy Rating Scheme (WERS)
www.wers.net

Contact:



Copyright 2006 Australian Window Association