

TECHNOLOGY IN MOTION



# MACO SURFACES



Expertise in surface technology

**MACO  
SURFACES**



MACO offers a total of seven different methods for surface application, all developed in-house. This means that in addition to its 95% vertical integration for in-house production, MACO has the widest range of methods for hardware surface finishing in the construction business, all of which can be applied to the hardware as part of the company's internal production processes.



**The right surface for every application**



## Contents

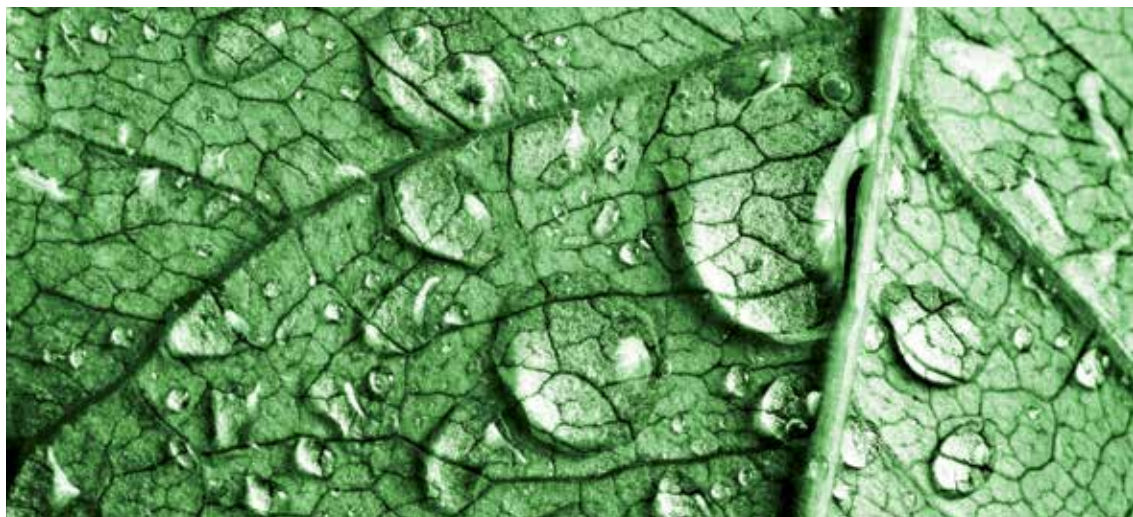

	Pages
Why is surface protection needed?	4
What is corrosion?	5
Materials processed by MACO	6
MACO surface technology	7
• MACO silver-look	8 – 9
• MACO TRICOAT-PLUS	10 – 11
• Powder coating	12
MACO PREMIUM-PLUS	13 – 14
• Anodizing	15
• Wet varnishing	16
• Vacuum deposition	17
• Plastic coating	18
Tested according to standard EN 13126	19
Tested according to standard EN 1670	20
Surface quality testing	21
Preservation of surface protection for hardware components	22 – 23



## Why is surface protection needed?



- Does the base material protect against environmental influences/corrosion?
- Aesthetics – decorative design options
- Improvement of technical properties (shearing, wearing properties, etc.)



## What is corrosion?



**Corrosion means the attack and destruction of metallic materials by chemical or electrochemical reactions with substances from the environment.**

### **What are corrosive agents?**

Corrosive agents are substances that surround the component and act on the material, causing corrosion, e.g. air, the atmosphere with or without industrial pollution, the marine atmosphere, water, condensed water, soil or chemicals.

### **What is coating metal corrosion?**

White rust forms initially on steel parts protected with zinc (corrosion coating metal). This is because zinc is less noble than steel and therefore acts as a sacrificial anode. That is, as long as zinc is applied to the immediate vicinity of the corrosion point, the steel cannot rust.

### **Types of corrosion**

Different types of corrosion may occur depending on the nature of the material and the respective corrosive agent. This includes uniform surface corrosion, cavity and pitting corrosion, contact and crevice corrosion, selective corrosion as well as stress and vibration-related corrosion.

### **Rusting of ferrous materials = base metal corrosion (ferrous rust)**

Due to the action of corrosive agents on iron-based materials, a loose, red-brown layer of hydrous iron oxides is formed.

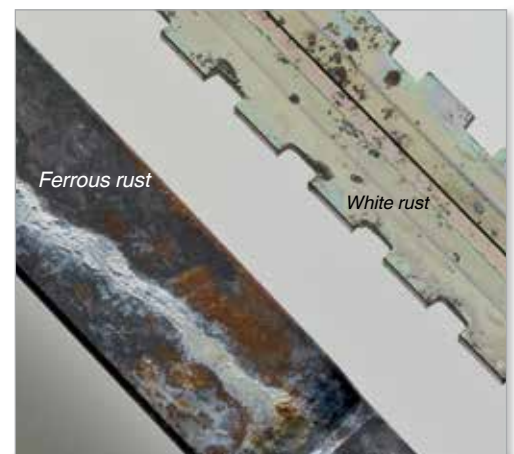



## Materials processed by MACO

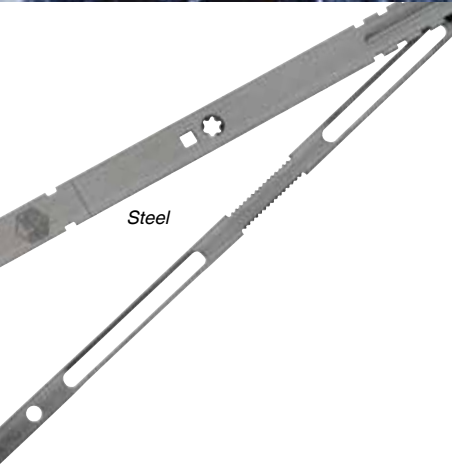

**MACO uses steel, ZAMAK, aluminium and PVC in the production of hardware. The final surface finish ensures corrosion protection and defines the appearance of the hardware components in terms of colour and surface texture.**

### **Steel**

Cuffs, bolts, RUSTICO shop fitting parts and various small parts are made of high quality cold-rolled band and sectional steels.

### **ZAMAK (zinc-base die-casting alloy)**

Strikers, bands and various small parts are produced in a high quality die-cast zinc alloy process.



### **Aluminium**

Window and door handles are made from an anodizable aluminium alloy.

### **PVC**

Handles, caps, bushings and other small parts are made from various synthetic materials.





## MACO surface technology



### **Broadest range of industries**

- Seven different surface methods
- Application on hardware during the course of in-house production

<b>Application methods</b>	<b>MACO hardware solutions</b>
<b>MACO silver-look</b>	MULTI turn and T&T hardware, PROTECT door locks, RAIL-SYSTEMS slide hardware, ESPAGS espagnolettes PRO-DOOR front-door hinge plates
<b>MACO TRICOAT-PLUS</b>	MULTI turn and T&T hardware, PROTECT door locks, RAIL-SYSTEMS lift & slide hardware, ESPAGS espagnolettes
<b>Powder coating</b>	RUSTICO shutter fittings in PREMIUM-PLUS, MULTI pivot post and scissor stay hinges, EMOTION window handles, PROTECT door locks and PRO-DOOR door hinges
<b>Anodizing</b>	EMOTION window handles, RAIL-SYSTEMS HS gear cuffs
<b>Wet varnishing</b>	Article from the EMOTION window handles range
<b>Vacuum deposition</b>	Caps (gold and chrome)
<b>Plastic sheath</b>	EMOTION window handle <i>resist</i>



## MACO silver-look



Back in the year 2000 MACO was the first manufacturer of building hardware to use chrome-VI-free silver passivation followed by silicate-based sealing in their electrogalvanising process. This process achieved excellent surface characteristic results and was the first alternative to chromating with chromium VI. To meet the future requirements of health-related and environmentally safe production methods, MACO already dispensed with the use of a cobalt-containing passivation processes at the beginning of 2014.

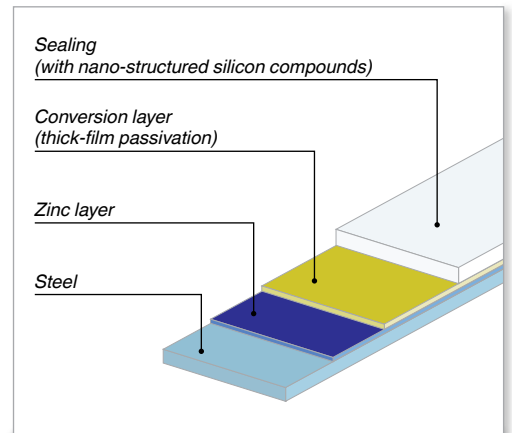

*Fittings manufactured from steel or die-cast zinc are galvanised, passivated and sealed.*

*Thick-layer passivation and sealing serves to improve the corrosion resistance and the appearance of zinc coatings on metal.*



## MACO silver-look



### High corrosion resistance based on environmentally friendly processes

Within the framework of state-of-the-art systems and ongoing development particularly in electroplating (sealing with nano-structured silicon compounds), MACO has been successful in fulfilling the requirements of Class 5 in accordance with EN 1670:2008 for turn and turn&tilt hardware.

The coating process in question is an exceptionally environmentally friendly process that does not require the use of chromium VI or cobalt.

### Application areas

Electrogalvanised fittings have proved to be ideal for normal stresses. Nevertheless, despite Class 5, these are only applicable to a limited extent for higher stresses such as damp room, food processing companies, coastal areas, certain types of timber etc. This is due to the chemical reaction of the zinc coating to aggressive materials.

In application areas for which a high chemical resistance is required, MACO TRICOAT PLUS hardware should be used.



### Fabricator benefits

- High-quality silver-look surface finish
- The highest corrosion resistance with Class 5 in accordance with EN 1670:2008
- Ideally suited for normal environmental influences/application areas
- Quality leadership on the strength of our decade-long experience in the field of electrogalvanising
- Our window and door hardware is enhanced in ten electrogalvanising plants in our modern in-house production facilities.



## MACO TRICOAT-PLUS



MACO TRICOAT PLUS hardware has been specially developed for applications that require enhanced corrosion protection.

The special feature of MACO TRICOAT PLUS hardware is that an organic top coat ('MKS' micro corrosion protection system) is applied on top of the electrogalvanised surface of the silver-look hardware. This coating system enables MACO TRICOAT PLUS hardware to achieve a very high level of chemical resistance and as a result, is far superior to electrogalvanised hardware with regard to corrosion.

### Ultimate corrosion resistance based on an environmentally friendly processes

The quality of the MACO TRICOAT-PLUS hardware is well above the requirements of Class 5 in accordance with EN 1670:2008. MACO guarantees this with the 15 year TRICOAT-PLUS surface guarantee for the use of MACO TRICOAT-PLUS fittings. With its innovative TRICOAT-PLUS surface coating process, MACO is the only hardware manufacturer who can offer a full range of highly corrosion-resistant products. As with the MACO silver-look surface finish, this is an exceptionally environmentally friendly process based on water-soluble varnishes.

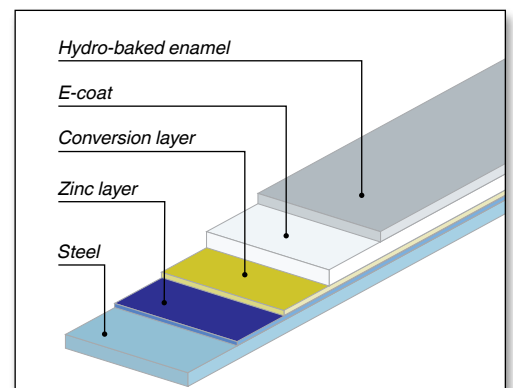

### What colours are available for MACO TRICOAT-PLUS fittings?

MACO TRICOAT-PLUS is available exclusively in a light shade of grey (metallic light grey). This colour provides an aesthetic upgrade for all window and door elements.



## MACO TRICOAT-PLUS



### Application areas

Basically anywhere where corrosion resistance of the electrogalvanised surfaces is insufficient; for example, in coastal areas, industrially congested areas, damp rooms, industrial premises with high corrosion impact, timber containing acids (e.g. oak, Accoya®, etc.), indoor swimming pools, food processing companies such as butcher's shops, cheese dairies, etc.

### The following tests are undertaken in order to ensure consistently high quality

- Salt spray test
- Outdoor exposure test
- Cross-cut test
- Movement and durability testing

### Fabricator benefits

- Differentiating characteristics
- Unrivalled aesthetics
- Durability under extreme conditions
- Ultimate corrosion resistance
- No corrosion during construction phase compared to galvanic zinc plating
- Solutions for problematic application areas
- Standard range in stock
- Processing and maintenance such as MACO silver-look
- Proven quality through tests such as: salt spray tests in accordance with EN ISO 9227, weathering tests, etc.
- 15 year surface-finish guarantee for use of MACO TRICOAT-PLUS hardware
- 10 year surface-finish guarantee for use of MACO TRICOAT-PLUS with Accoya® and oak.
- Available for MACO MULTI-MATIC turn and T&T hardware, MACO PROTECT door locks, MACO RAIL-SYSTEMS lift & slide hardware, MACO ESPAGS espagnolettes



## Powder coating



**MACO uses the powder coating method for MULTI pivot post and scissor stay hinges, RUSTICO shop fittings, PROTECT door locks, PRO-DOOR hinges and EMOTION handles. The advantage of powder coating is the environmental friendliness of the fabrication process. In addition, the powder coating provides a high level of corrosion protection, it is scratch resistant, and is water and stain resistant, thereby protecting fittings against aggressive environmental influences.**

### MACO colours

Powder coated fittings are available in different RAL colours. Other RAL colours are available on request. All RAL classic colours are available to choose from in this respect.

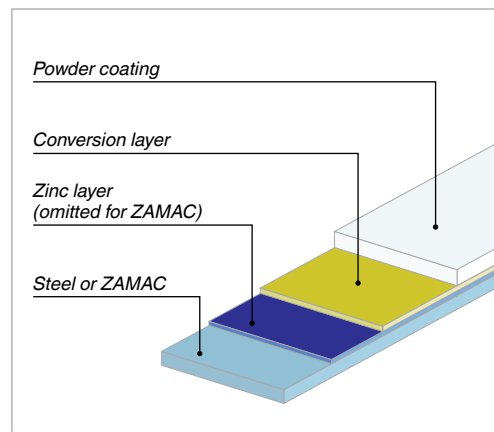

*(The layer structure differs for RUSTICO shop fittings)*





## MACO PREMIUM-PLUS



**MACO RUSTICO shutter fittings are exposed to the effects of weathering. Thanks to its incredibly high corrosion resistance, the new PREMIUM PLUS surface puts everything else in the shade. It is the result of targeted MACO research and development work in cooperation with external partners.**

### Unrivalled resistance

- 10-year surface guarantee
- Certification of over 2000 h corrosion resistance with test report from ift Rosenheim in accordance with EN 1670:2008
- Tested quality through internal tests, such as: salt spray tests in accordance with EN ISO 9227, weathering tests, etc.

### Application areas

MACO RUSTICO shutter fittings are suitable for use in all locations, including coastal regions. The lifetime can be increased under corrosive conditions by ensuring regular maintenance (cleaning and oiling).



## MACO PREMIUM-PLUS



### **MACO colours**

MACO RUSTICO shutter fittings come in grey, white and black. MACO offers its customers all RAL Classic colours at a surcharge.



### **Fabricator benefits**

- Stand out from the competition
- 2000 h corrosion resistance in accordance with EN 1670:2008 verified by ift Rosenheim
- 10-year surface guarantee
- Especially suitable for shops in coastal areas
- Elegant appearance with fine structure
- High colour fastness
- Durable, scratch-resistant surface with water and dirt repellent properties
- Environmentally friendly technology



## Anodizing



Suitable electrolytes with anodic process with the help of DC and/or AC

- Hard
- Wear-resistant
- Weatherproof and
- decorative oxide coating applied to the surface of the EMOTION handles and RAIL SYSTEMS lift&slide gear cuffs

It is possible to produce aluminium surfaces in a variety of colours

### MACO colours

MACO anodized in the following colours:  
Handles: Champagne, Bronze, Brown, Titan and Silver

Lift&slide gear cuffs: Silver, Brown and Bronze

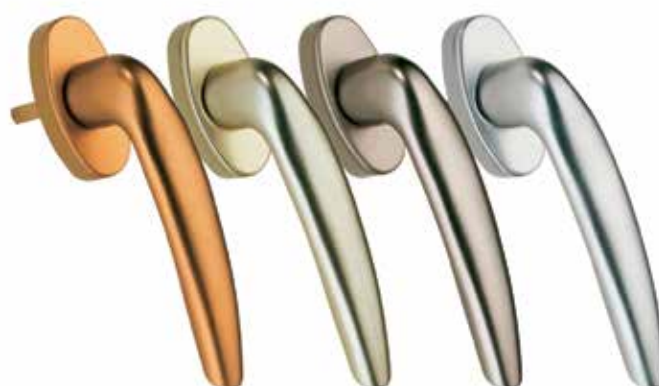



## Wet varnishing



**Depending on requirements, wet spray painting is undertaken according to the following procedures for the EMOTION handle range (shell handles, door plates, rosettes, caps) and cover caps for MULTI pivot posts.**

1. Manual spray painting
2. Automatic surface spray painting
3. Automatic drum spray painting

Through the use of hydro paints (water-based paints) a wide variety of colours are applied in an extremely environmentally friendly process.

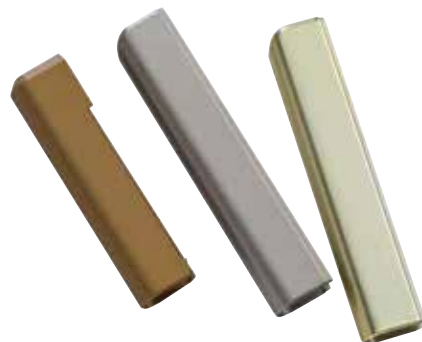



## Vacuum deposition



**This method utilises a vacuum chamber and aluminium wire which is evaporated at high temperature. This vapour is then applied to the workpieces by means of the vacuum.**

The parts are then coated with a special protective clear lacquer. This lacquer can also be dyed. The protective layer is hardened and made wear resistant by means of high temperature drying. The vacuum evaporation process is used primarily for MACO PVC covers in gold and chrome.

### Advantages

- This method enables special high-gloss surfaces (metallic effect) to be created.





## Plastic sheath



Injection moulding technology is utilised to coat a die-cast zinc core with a PVC layer for the MACO EMOTION HARMONY *resist* window handle.

- Extremely durable plastic surfaces
- Perfect visual properties (colour, gloss)
- Very high resistance to mechanical loads
- Good chemical resistance
- Good long term performance
- No corrosion

### **HARMONY *resist* window handles**

- The stable metal core is covered with a 3 mm PVC protective coating.
- The surface is extremely robust.
- Scratches and other signs of wear and tear are hardly visible.

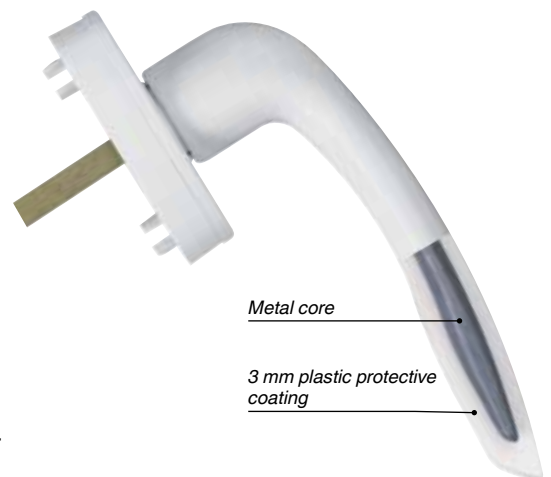



## Tested according to standard EN 13126



**EN 13126 is the standard for architectural hardware and fittings for windows and doors. This standard defines the requirements for test methods for lasting functionability, strength, security and operation. It is divided into 19 parts, which cover all types of windows and doors.**

### **What does this standard specify in terms of corrosion resistance?**

EN 1670 designates that fittings must correspond to the classes specified in the standard, whereby at least Class 3 must be achieved.

### **Excluded from the assessment are**

- Riveted areas
- Subsequently processed areas, for example, cut fittings
- Parts where the surfaces have not been processed, provided they are not in the visible range of the fittings
- Welds and their immediate surroundings



## Tested according to standard EN 1670



### **EN 1670 is the standard for corrosion resistance of locks and building hardware.**

The corrosion resistance is divided into 5 classes

<b>Class 1</b>	24 hours	Low resistance for indoor use in dry environments
<b>Class 2</b>	48 hours	Moderate resistance for indoor areas where condensation / moisture can occur
<b>Class 3</b>	96 hours	High resistance for outdoor areas where occasionally or frequently, moisture, rain or dew may occur
<b>Class 4</b>	240 hours	Outdoor areas with very harsh conditions
<b>Class 5</b>	480 hours	Outdoor areas with exceptionally harsh conditions where long-term protection of the product is required

### **The key points**

The required corrosion tests must be carried out on assembled parts as they correspond to normal delivery conditions.

Only the corrosion of the base material is rated during the assessment, white rust is excluded from the review. Screws and fasteners sold together with the hardware product must also comply with the standard.

Test certificates and test reports are available on our website at [www.maco.at](http://www.maco.at)



## Quality testing of the surfaces



**MACO is certified to ISO 9001 (quality), ISO 14001 (Environment) and OHSAS 18001 (occupational health and safety). All processes and procedures are defined.**

**The entire production process is secured by an in-house production control system**

A continuous process control system is achieved on the basis of the obtained values.

The individual processes are specified in detail by means of working instructions. This ensures constant surface quality and corrosion resistance.

Monitoring is carried out by external certified test institutes.



### Test methods

- Salt spray tests in accordance with EN ISO 9227
- Climate change test
- Xenon test to ensure UV resistance
- Cross-cut test
- Layer thickness measurement
- Layer thickness determination by means of micrograph
- Abrasion test
- Nail scratch test
- Colour measurement
- Detergent test
- Outdoor exposure test



## Preservation of surface protection for hardware components



**A series of regulations must be observed to ensure the proper functions of the window hardware. The following points should be taken into account so that end users can enjoy perfect operation and aesthetics of the windows and hardware.**

### **Causes of corrosion on hardware components**

Should signs of corrosion on hardware components develop after a short period of time in individual cases (despite surface protection), the following listed points are generally the cause of corrosion:

- a) The actual cause of corrosion is the atmospheric oxygen. In practice however, corrosion only appears, when the relative humidity reaches a critical value of approx. 60 to 70 %.
- b) An additional cause of corrosion can be the formation of condensation on the metal components; due to passing below the dew point during severe fluctuation of temperatures.
- c) Corrosion attacks have increased due to gaseous air pollution (industrial atmosphere, car exhaust emissions) e.g. sulphur dioxide ( $\text{SO}_2$ ) and nitrogen oxide gases ( $\text{NO}_2$ ) and resulting compounds in the presence of humidity - sulphurous acid ( $\text{H}_2\text{SO}_3$ ), sulphuric acid ( $\text{H}_2\text{SO}_4$ ), nitric acid ( $\text{HNO}_3$ ).  
This air pollution also has a corrosive effect in a dry condition.
- d) The location of the object affect must be taken into account in connection with point c) above, e.g. busy roads, industrial areas, waste water treatment plants, sea air, air containing chlorine, intensive livestock breeding, etc.
- e) Also harmless materials e.g. paper/card-board as well as different types of timber used in the fenestration industry partially contain aggressive components (acids, alkali, chlorides) that can destroy the passivation upon contact and thus cause corrosion.
- f) Plaster, cement and other building materials e.g. acetic acid cross-linked silicone as is used frequently in the fenestration, industry, are additional causes for corrosion.
- g) A common and not sufficiently recognised source of damage is cleaning by chemical attack (acetic cleaning, agents, acidic cleaning agents with citric acid, cement residue remover with phosphoric acid, severe alkaline cleaning agents, etc.) or by means of mechanical abrasion (abrasive cleansers, steel wool), which destroys the passivation and, as a result, accelerates corrosion attack.
- h) In coastal areas, sea water may settle on the fittings in the form of spray and form corrosive salt deposits.



## Preservation of surface protection for hardware components

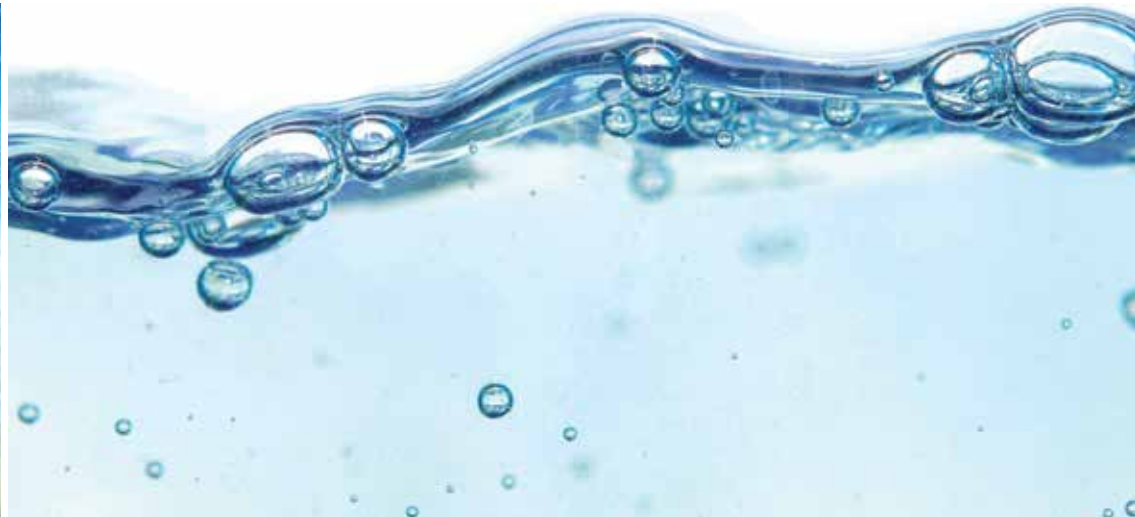

### Measures to preserve the surface-finish

- The hardware and/or the rebate areas must be ventilated sufficiently – in particular during the building phase – so that they are not exposed to direct wetness impact or to condensation.
- The hardware must be kept free from deposits and soiling from building materials (building dust, plaster, cement etc.); this means that the windows must be covered appropriately.
- Aggressive vapours in conjunction with small formations of condensation can lead to fast corrosion on the hardware components.
- Timber frames and sashes with a high concentration of (tannic) acid must be treated with suitable surface coatings to ensure that these contents do not evaporate from the timber.
- No acetic-acid or cross-linked acidic sealing compounds or those with the above mentioned contents may be used.
- The fittings may only be cleaned or polished with mild, pH-neutral cleaning agent in diluted form.
- The hardware may not be damaged with sharp edged tools.

**MACO  
SURFACES**



**MAYER & CO BESCHLÄGE GMBH**  
ALPENSTRASSE 173  
A-5020 SALZBURG  
TEL +43 662 6196-0  
FAX +43 662 6196-1449  
maco@maco.at  
www.maco.at

**MACO DOOR & WINDOW  
HARDWARE (U.K.) LTD**  
CASTLE ROAD EUROLINK  
IND CENTRE SITTINGBOURNE  
KENT. ME10 3LY  
TEL +44 1795 433900  
FAX +44 1795 433902  
enquiry@macouk.net  
www.macouk.net

 Scan for more Info

