



PRODUCT FILE
LP 01 MU8 01 TEC

OTLAV

r e p o r t
COSTANT PROCESS CONTROL

UNIVERSAL ROD

Dossier
UT FP MM 01

Certificate
GS 01 MU 801 TES

Product Code
MU 801

Santa Lucia di Piave
02/05/01

Technical Manager
Luca T. L.

Production Manager
S. M.

Fabio Padovan
Sole Administrator
F. P.

MATERIALS

MILLIMETRIC ROD:
Light Alloy UNI 3571 UNI 3569-66, UNI 6170-68

BUSHINGS:
Steel UNI 4838 Carbonitrided

TEMPLATES, REVERSIBLE STOP, SHIMS:
Low Density or Light Alloy Technopolymer UNI 3571 UNI 3569-66, UNI 6170-68

KNOBBS: Thermosetting Duroplast and Steel
Materials UNI 5105 or similar

SCREWS:
Steel C22 B EN 119-74 Hardened and Tempered

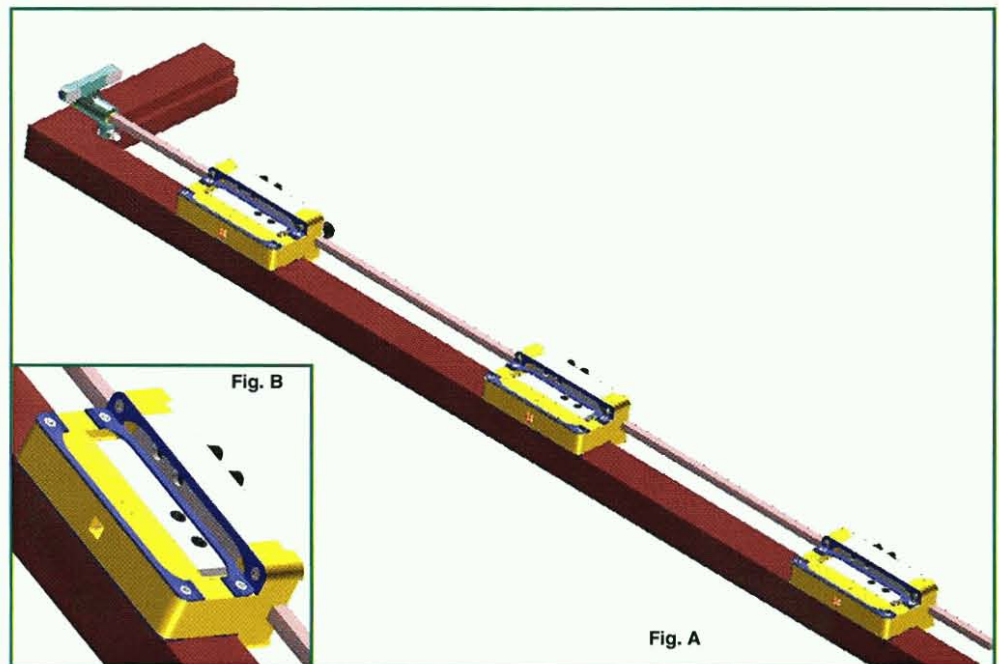

FEATURES

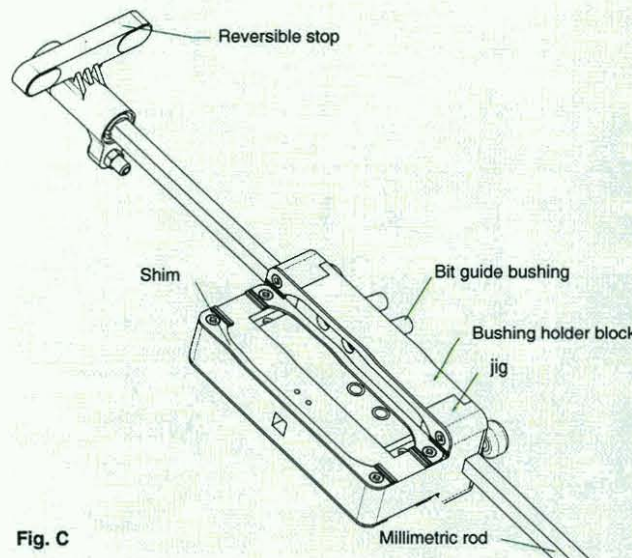

The UNIVERSAL rod is designed to fit one or more special jigs that permit separate door and frame drilling for subsequent hinge fitting.

The door does not therefore have to be positioned on the frame as in the case of standard jigs.

The rod of the UNIVERSAL rod is millimetric to ensure highly-precise jig positioning.



OTLAV S.p.A.
via Volta 26
31025 S. Lucia di Piave (TV)
ITALY
tel +39 0438 460 777
fax +39 0438 468 000
web: www.otlav.com
email: info@otlav.it

UNIVERSAL ROD

The special symmetric shape of the tools and the reversible stop ensure the same rod can be used both for doors and frames, whether right or left. Thanks to the millimetric rod, the jigs and the stop can be precisely positioned without the need for continual measurements.

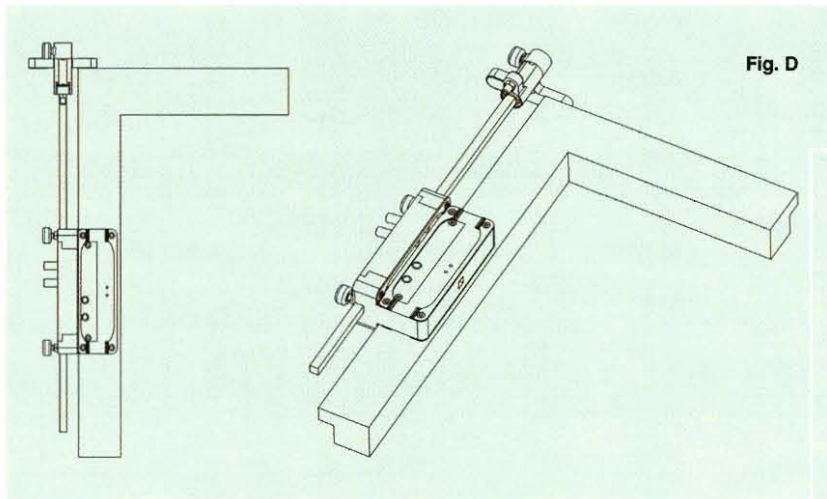

Fig. D

UNIVERSAL rod positioned on door.

Detail of REVERSIBLE STOP positioned on door.

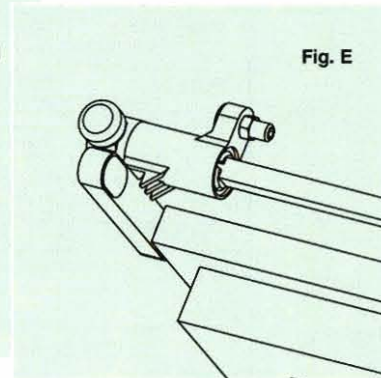

Fig. E

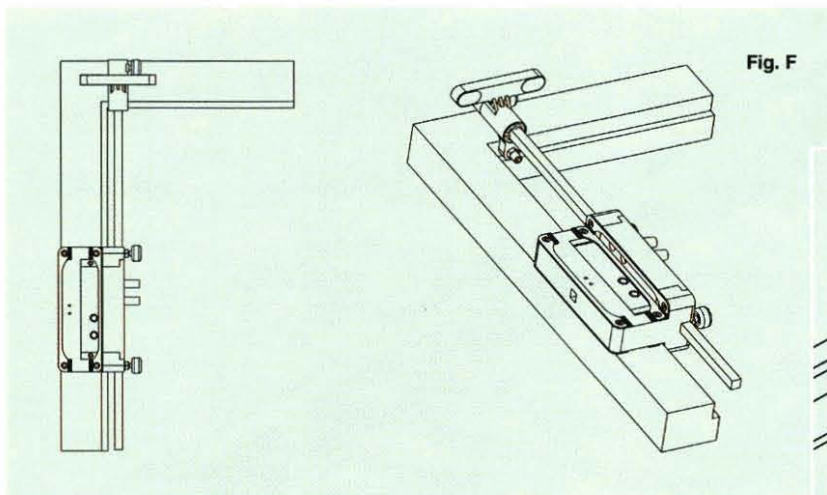

Fig. F

UNIVERSAL rod positioned on frame

Detail of REVERSIBLE STOP positioned on frame.

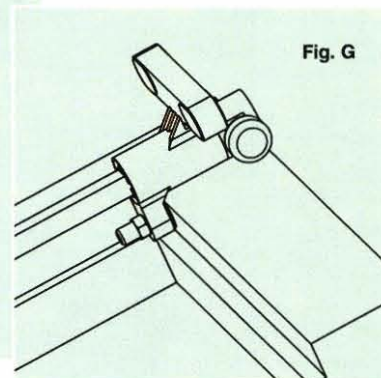

Fig. G

When suitably equipped, the UNIVERSAL rod permits fitting male pieces on frames, taking as reference the females already fitted on the door, for instance with automatic machines.

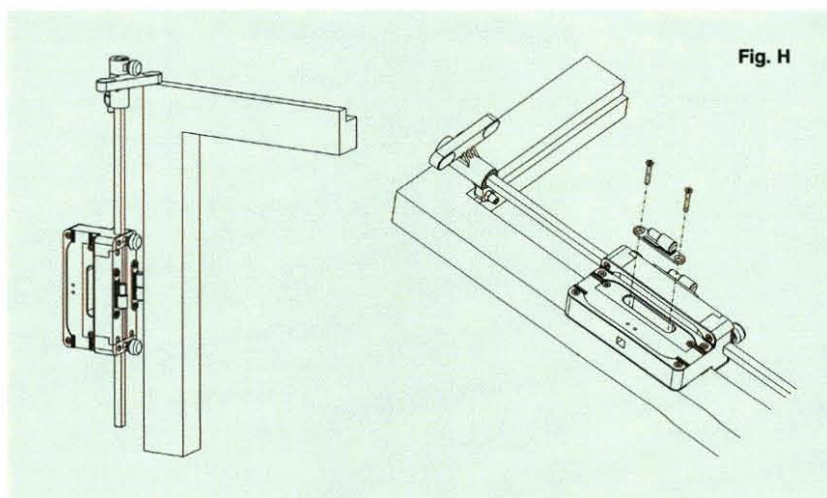

Fig. H

With the UNIVERSAL rod suitably equipped the females previously fitted to the door act as a reference for going on to fit the male on the frame.

STRONG POINTS

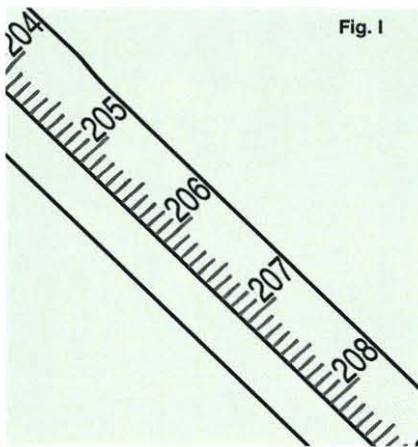

Fig. I

Compared to normal rods, the UNIVERSAL rod is extremely time saving because the door no longer has to be positioned on the frame, making it possible to also set up two distinct frame production lines - one for the doors and one for the frames.

The jigs of the UNIVERSAL rod can also be customised according to the type of profile, the type of hinge to be fitted, to the position and angle of the pins compared to the door or frame. A lot of time is also saved thanks to the **millimetric rod** (Fig. I) for correctly positioning the jigs without need for rulers or other measuring instruments. Finally, the use of shims permits adapting the jigs in the event of having to increase or decrease the drilling distance with respect to the door or frame.

NOTES:

The minimum distance between the top edge of the door and the first hinge is about 140 mm. In the event of this distance being excessive, using a specially modified stop, it is possible to move to a fixed measurement of about 85 mm. In this case, the reference on the frame is made directly by the jig, while the stop continues to carry out its function on the door (see Fig. L and Fig. M).

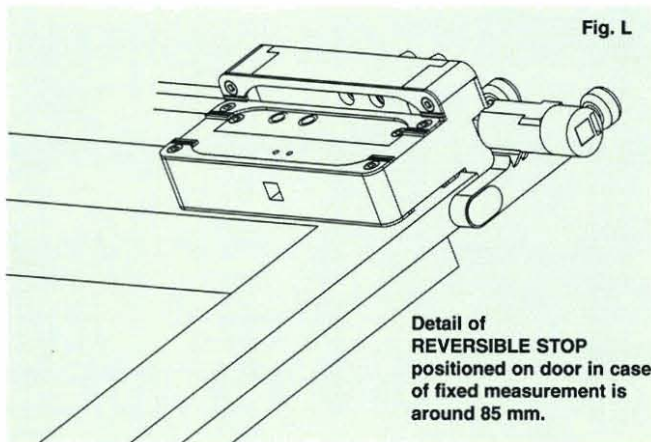

Fig. L

Detail of REVERSIBLE STOP positioned on door in case of fixed measurement is around 85 mm.

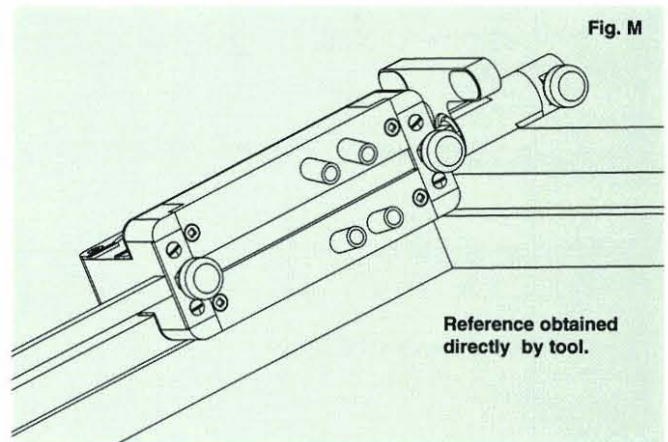

Fig. M

Reference obtained directly by tool.

CUSTOMISATION:

The UNIVERSAL rod jigs are customised for each single use. For this purpose, **the user must provide a SCALE drawing of the profile** (door plus frame) on which the UNIVERSAL rod is to be used, carefully specifying the basic dimensions of the profile itself, the position in which the hinge will be fitted (see Fig. N) and the type of hinge to be fitted.

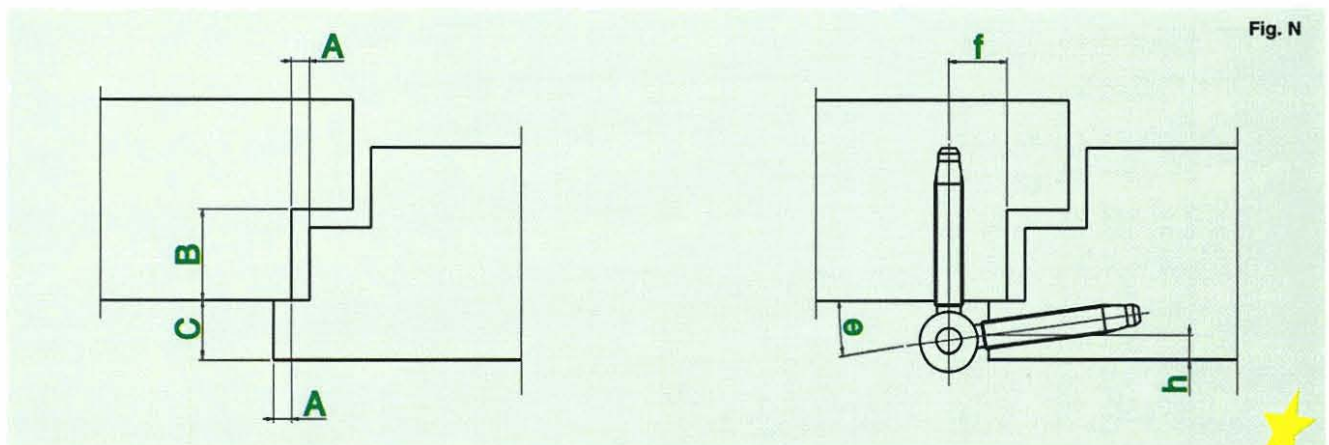

Fig. N



USE FILE
LP 01 MU8 01 USE

Dossier
UT FP MM 01

Product File
LP 01 MU8 01 TEC

Certificate
GS 01 MU 801 TES

Product Code
MU 801

Santa Lucia di Piave
02/05/01

Technical Manager

Fabio Padovan
Sole Administrator



OTLAV S.p.A.
via Volta 26 / P.O. Box 64
31025 S. Lucia di Piave (TV)
ITALY
tel +39 0438 460 777
fax +39 0438 468 000
web: www.otlav.com
email: info@otlav.it

U S E

r e p o r t

COSTANT PROCESS CONTROL

UNIVERSAL ROD

ADJUSTING THE REVERSIBLE STOP

Adjust distance **S** between the support plate for the inside of the frame (**A**) and the support surface for the external part of the door (**B**), by means of the threaded pin (**C**) using an hexagonal key ch4 (**D**) and block in the desired position by means of locknut (**E**) (Figure 1).

Distance **S** represents the measurement that corresponds to the extent that the door surmounts the frame.

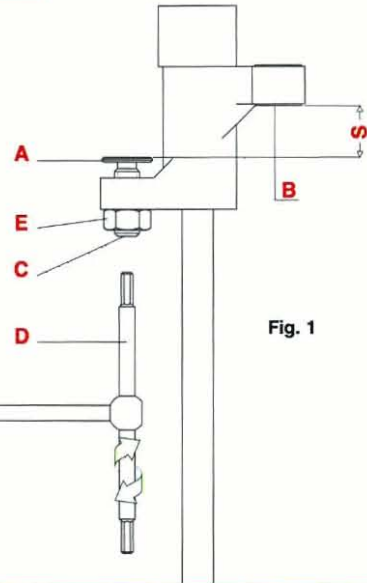
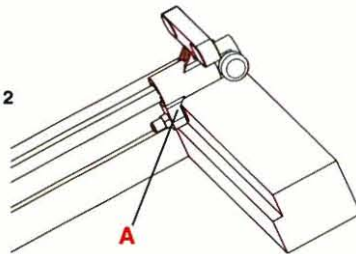

Fig. 1

FITTING MALES ON FRAME

Fig. 2



1) Rest the rod on the frame by taking the support plate (**A**) into contact with the internal rabbet of the frame (Figure 2) and the reference surfaces of the jigs into contact with the relevant frame surfaces (Figure 3).

Fig. 3

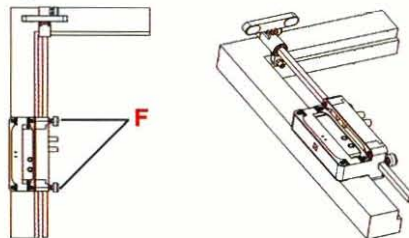

2) Position the jigs at the desired distance, if necessary with the aid of the millimetric scale on the aluminium rod and then block these on the rod in the desired position by tightening knobs (**F**).

Fig. 4

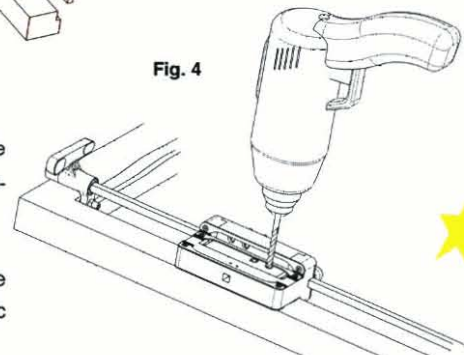

3) Drill the frame using the bit guide bushings (Figure 4). Repeat the operation for each jig.

4) Last operation: fit the males on the frame according to the specific instructions for the hinge.

FITTING THE FEMALES ON THE DOOR

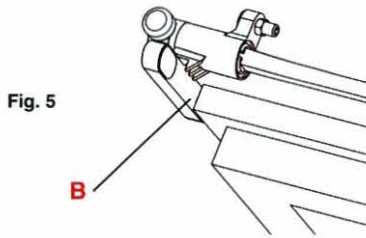

Fig. 5

1) Rest the rod on the door and take the support surface for the external part of the door (B) into contact with the top edge of the door (Figure 5) and the reference surfaces of the jigs into contact with the relevant door surfaces (Figure 6).

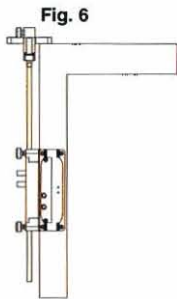

Fig. 6

2) Position the jigs at the desired distance, if necessary with the aid of the millimetric scale on the aluminium rod and then block these on the rod in the desired position.

3) Drill the frame using the bit guide bushings (Figure 7). Repeat the operation for each jig.

4) Last operation: fit the females on the door according to the specific instructions for the hinge.

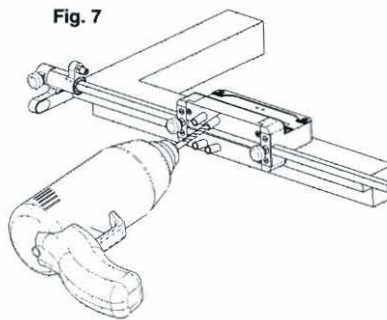

Fig. 7

NOTE

1) To switch from frame drilling to door drilling and vice versa, simply turn the entire rod round by 180° and rotate the moving part of the reversible stop, always by 180°.

2) Obviously, to ensure correspondence between door and frame, the jigs and the reversible stop must not be moved from their position during the drilling operation switch.

FITTING MALES ON THE FRAME WITH REFERENCES TO FEMALE ALREADY FITTED ON DOOR

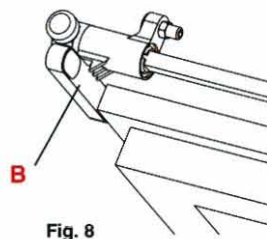

Fig. 8



Fig. 9

1) Move into contact the support surface for external door (B) on the top of the door (Fig. 8) and move the sample males (H) on the templates against the females (G) already fitted on the door and secure the templates on the rod (Figure 9).

NOTE

It is best to keep the reversible stop always blocked in the same position on the rod, for instance with the support surface for the external part of the door aligned with the zero.

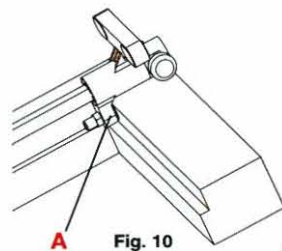
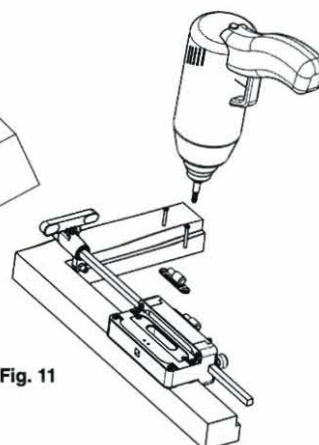

Fig. 10

2) Position the rod on the frame and move the plate (A) up against the internal rabbet of the frame (Figure 10) and the reference surfaces of the jigs into contact with the relevant surfaces of the frame.

In the case of male with plate (eg. P09), fit the male in the relevant housing and secure using the special screws (Figure 11).

Fig. 11



In the case of standard male, proceed as at points 3 and 4 of FITTING MALES ON FRAME section.



CERTIFICATE
GS 01 MU 801 TES

Dossier
UT FP MM 01

Product Code
MU 801

Santa Lucia di Piave
02/05/01

Quality Manager
[Signature]

Technical Manager
[Signature]

Fabio Padovan
Sole Administrator
[Signature]



OTLAV S.p.A.
via Volta 26
31025 S. Lucia di Piave (TV)
ITALY
tel +39 0438 460 777
fax +39 0438 468 000
web: www.otlav.com
email: info@otlav.it



r e p o r t
COSTANT PROCESS CONTROL

UNIVERSAL ROD

MATERIALS: See Tech File LP 01 M801 01 TEC

1) DIMENSIONAL CONTROL TEST

The UNIVERSAL rod has undergone standard dimensional testing of significant parts.
Such testing was successful.

2) SIGHT CONTROL TEST

The UNIVERSAL rod has undergone sight control testing as regards both surface condition and colour.
Such testing was successful.

3) BENDING TEST:

The square rod of the UNIVERSAL rod has undergone a bending test simulating normal use.
Such testing was successful.

OVERALL TEST RESULTS

UNIVERSAL ROD Article Prototype:

- SUCCESSFUL
- REJECTED
- UNSUCCESSFUL



View of the Otlav Test Laboratory